

**BAHAGIAN PENGURUSAN SEKOLAH BERASRAMA PENUH
DAN SEKOLAH KECEMERLANGAN**

MODUL PERFECT SCORE
SEKOLAH BERASRAMA PENUH TAHUN 2014

ADDITIONAL MATHEMATICS

Panel Penyedia:

- 1. TN HJ MOHD RAHIMI BIN RAMLI**
SEK MEN SAINS SULTAN MAHMUD .(SESMA)
- 2. PN NORIZAH BINTI RAHMAT**
SEKOLAH MENENGAH SAINS JOHOR (SMSJ)
- 3. PN SARIPAH BINTI AHMAD**
SM SAINS MUZAFFAR SYAH, MELAKA.(MOZAC)
- 4. PN SABARIAH BINTI SAMAD**
SM SAINS REMBAU (SEMESRA)
- 5. EN ABDUL RAHIM BIN BUJANG**
SEKOLAH TUN FATIMAH (STF)
- 6. EN ABDUL RAHIM BIN NAPIAH**
SM SAINS TUN SYED SHEH SHABUDIN (STSSS)

The following formulae may be helpful in answering the questions. The symbols given are the ones commonly used.

ALGEBRA

$$1. x = \frac{-b \pm \sqrt{b^2 - 4ac}}{2a}$$

$$2. a^m \times a^n = a^{m+n}$$

$$3. a^m \div a^n = a^{m-n}$$

$$4. (a^m)^n = a^{mn}$$

$$5. \log_a mn = \log_a m + \log_a n$$

$$6. \log_a \frac{m}{n} = \log_a m - \log_a n$$

$$7. \log_a m^n = n \log_a m$$

$$8. \log_a b = \frac{\log_c b}{\log_c a}$$

$$9. T_n = a + (n-1)d$$

$$10. S_n = \frac{n}{2}[2a + (n-1)d]$$

$$11. T_n = ar^{n-1}$$

$$12. S_n = \frac{a(r^n - 1)}{r - 1} = \frac{a(1 - r^n)}{1 - r}, r \neq 1$$

$$13. S_\infty = \frac{a}{1 - r}, |r| < 1$$

CALCULUS

$$1. y = uv, \quad \frac{dy}{dx} = u \frac{dv}{dx} + v \frac{du}{dx}$$

$$2. y = \frac{u}{v}, \quad \frac{dy}{dx} = \frac{v \frac{du}{dx} - u \frac{dv}{dx}}{v^2}$$

$$3. \frac{dy}{dx} = \frac{dy}{du} \times \frac{du}{dx}$$

4. Area under a curve

$$= \int_a^b y dx \quad \text{or}$$

$$= \int_a^b x dy$$

5. Volume of revolution

$$= \int_a^b \pi y^2 dx \quad \text{or}$$

$$= \int_a^b \pi x^2 dy$$

GEOMETRY

$$1. \text{Distance} = \sqrt{(x_2 - x_1)^2 + (y_2 - y_1)^2}$$

2. Mid point

$$(x, y) = \left(\frac{x_1 + x_2}{2}, \frac{y_1 + y_2}{2} \right)$$

3. Division of line segment by a point

$$(x, y) = \left(\frac{nx_1 + mx_2}{m+n}, \frac{ny_1 + my_2}{m+n} \right)$$

4. Area of triangle

$$= \frac{1}{2} |(x_1 y_2 + x_2 y_3 + x_3 y_1) - (x_2 y_1 + x_3 y_2 + x_1 y_3)|$$

$$5. |r| = \sqrt{x^2 + y^2}$$

$$6. \hat{r} = \frac{x\hat{i} + y\hat{j}}{\sqrt{x^2 + y^2}}$$

STATISTICS

$$1. \bar{x} = \frac{\sum x}{N}$$

$$2. \bar{x} = \frac{\sum fx}{\sum f}$$

$$3. \sigma = \sqrt{\frac{\sum (x - \bar{x})^2}{N}} = \sqrt{\frac{\sum x^2}{N} - \bar{x}^2}$$

$$4. \sigma = \sqrt{\frac{\sum f(x - \bar{x})^2}{\sum f}} = \sqrt{\frac{\sum fx^2}{\sum f} - \bar{x}^2}$$

$$5. m = L + \left(\frac{\frac{1}{2}N - F}{f_m} \right) C$$

$$6. I = \frac{Q_1}{Q_0} \times 100$$

$$7. \bar{I} = \frac{\sum W_i I_i}{\sum W_i}$$

$$8. {}^n P_r = \frac{n!}{(n-r)!}$$

$$9. {}^n C_r = \frac{n!}{(n-r)!r!}$$

$$10. P(A \cup B) = P(A) + P(B) - P(A \cap B)$$

$$11. P(X = r) = {}^n C_r p^r q^{n-r}, p + q = 1$$

$$12. \text{Mean, } \mu = np$$

$$13. \sigma = \sqrt{npq}$$

$$14. Z = \frac{X - \mu}{\sigma}$$

TRIGONOMETRY

$$1. \text{Arc length, } s = r\theta$$

$$2. \text{Area of sector, } A = \frac{1}{2} r^2 \theta$$

$$3. \sin^2 A + \cos^2 A = 1$$

$$4. \sec^2 A = 1 + \tan^2 A$$

$$5. \operatorname{cosec}^2 A = 1 + \cot^2 A$$

$$6. \sin 2A = 2 \sin A \cos A$$

$$7. \begin{aligned} \cos 2A &= \cos^2 A - \sin^2 A \\ &= 2 \cos^2 A - 1 \\ &= 1 - 2 \sin^2 A \end{aligned}$$

$$8. \sin(A \pm B) = \sin A \cos B \pm \cos A \sin B$$

$$9. \cos(A \pm B) = \cos A \cos B \mp \sin A \sin B$$

$$10. \tan(A \pm B) = \frac{\tan A \pm \tan B}{1 \mp \tan A \tan B}$$

$$11. \tan 2A = \frac{2 \tan A}{1 - \tan^2 A}$$

$$12. \frac{a}{\sin A} = \frac{b}{\sin B} = \frac{c}{\sin C}$$

$$13. a^2 = b^2 + c^2 - 2bc \cos A$$

$$14. \text{Area of triangle} = \frac{1}{2} ab \sin C$$

**ANALISIS KERTAS PEPERIKSAAN SIJIL PELAJARAN MALAYSIA
MATEMATIK TAMBAHAN (2007 – 2013)**

Kertas / Paper 1 (3472/1)

TAJUK	2007	2008	2009	2010	2011	2012	2013
Fungsi Functions	1,2,3	1,2,3	1,2,3	1,2,3	1,2,3	1,2,3	1,2,3
Persamaan Kuadratik Quadratic Equations	4	4	4	5	4	4,5	4
Fungsi Kuadratik Quadratic Functions	5,6	5,6	5,6	4,6	5,6	6	5,6
Indeks & Logaritma Indices & Logarithms	7,8	7,8	7,8	7,8	7,8	7,8	7,8
Janjang Progressions	9,10,11	9,10,11	9,10,11	9,10,11	9,10,11	9,10,11	9,10,11
Hukum Linear Linear Law	12	12	-	12	12	12	12
Koordinat Geometri Coordinate Geometry	13,14	13,14	15	13,14	13	13,14	13,14
Vektor Vectors	15,16	15,16	13,14	15,16	16,17	15,16	15,16
Sukatan Membulat Circular Measures	18	18	12	17	18	18	17
Fungsi Trigonometri Trigonometry Functions	17	17	16,17	18	14,15	17	18
Pembezaan Differentiation	19,20	19,20	19,20	20	20	19,20	19,20
Pengamiran Integrations	21	21	18,21	19,21	19,21	21	21
Statistik Statistics	22	22	24	22	22	22	22
Pilihatur & Gabungan Permutations & Combinations	23	23	22,23	23	23	23	23
Kebarangkalian Probability	24	24	-	24	24	24	24
Taburan Kebarangkalian Probability Distributions	25	25	25	25	25	25	25

Kertas / Paper 2 (3472/2)

TAJUK	2007	2008	2009	2010	2011	2012	2013
<i>Section / Bahagian A</i>							
<i>Persamaan Serentak Simultaneous Equations</i>	1	1	1	1	1	1	1
<i>Janjang Progressions</i>	6	3	6	3	3	-	2
<i>Fungsi Kuadratik Quadratic Functions</i>	-	2	2	-	-	2	-
<i>Indeks & Logaritma Indices & Logarithms</i>	-	-	-	-	2	-	-
<i>Geometri Koordinat Coordinate Geometry</i>	2	-	-	5	5	-	-
<i>Vektor Vectors</i>	-	6	5	-	-	5	3
<i>Fungsi Trigonometri Trigonometry Functions</i>	3	4	4	2	6	6	4
<i>Pembezaan Differentiation</i>	4	-	3	-	-	3	5
<i>Pengamiran Integration</i>	-	-	-	4	-	-	-
<i>Statistik Statistics</i>	5	5	-	6	4	4	6
<i>Section / Bahagian B</i>							
<i>Hukum Linear Linear Law</i>	7	8	8	7	7	7	7
<i>Pembezaan Differentiation</i>	-	7	7	8	-	8	-
<i>Vektor Vectors</i>	8	-	-	9	10	-	-
<i>Pengamiran Integration</i>	10	-	-	-	8	-	8
<i>Koordinat Geometri Geometry Coordinate</i>	-	10	9	-	-	10	9
<i>Probability Distributions Taburan Kebarangkalian</i>	11	11	11	10	11	11	10
<i>Sukatan Membulat Circular Measures</i>	9	9	10	11	9	9	11
<i>Section / Bahagian C</i>							
<i>Motion Along a Straight Line Gerakan Pada Garis Lurus</i>	12	12	15	12	12	12	12
<i>Penyelesaian Segitiga Solutions of Triangles</i>	15	14	12	15	13	13	13
<i>Nombor Indeks Number Index</i>	13	13	13	13	14	14	14
<i>Pengaturcaraan Linear Linear Programming</i>	14	15	14	14	15	15	15

FORMAT OF QUESTION PAPER : ADDITIONAL MATHEMATICS PAPER 2 ; 3472/2

COMPONENT	TOPIC
ALGEBRA	Functions Quadratic Equations Quadratic Functions Simultaneous Equations Indices and Logarithms Progressions Linear Law
STATISTICS	Statistics Permutations and Combinations Probability Probability Distribution
TRIGONOMETRIC	Circular Measures Trigonometric Functions
CALCULUS	Differentiation Integration
GEOMETRY	Coordinate Geometry Vectors
APPLICATIONS OF SCIENCE AND TECNOLOGY	Solution of Triangles Motion Along a Straight Line
APPLICATION OF SOSIAL SCIENCE	Index Number Linear Programming

NO.	TOPIC	NO	TOPIC	NO	TOPIC
1.	Simultaneous Equations	7	Linear Law	12.	Motion Along a Straight Line
2.		8.		13.	Solution of Triangles
3.		9.		14.	Index Number
4.		10.	Circular Measures	15.	Linear Programming
5.	Trigonometric Functions	11.	Probability Distributions		
6.					
	40 marks		40 marks		20 marks

SENARAI SEMAK MENJELANG PEPERIKSAAN SPM



Topic	Subtopic	Concept	Check
FUNCTIONS	Relation	Arrow diagram, ordered pairs, graph - Object, image, domain, codomain , range, type of range,	
	Inverse	Comparison	
	Composite function	Comparison , find the function given the composite function	
QUADRATIC EQUATIONS	Root of Quadratic Equation	Find the root using formula	
	Equation of Quadratic Equation	Form quadratic equation (i) given roots (ii) α and β	
	Type of Roots	$b^2 - 4ac < 0$, $b^2 - 4ac = 0$, $b^2 - 4ac > 0$,	
QUADRATIC FUNCTION	Completing the square	Graph , maximum / minimum values/point , axis of symmetry Analysis of the graph (comparison with the CT^2)	
	Inequalities	Find the range o	
INDICES & LOGARITHMS	Indices	Solve the equations involving indices : same base, using log, factorisation	
	Logarithm	Solve the equation involving log : same base , different base “express – express” - laws of log	
PROGRESSIONS	AP	n^{th} -term , sum of the terms	
	GP	n^{th} -term, sum of terms, sum of infinity, decimal to fraction	
COORDINATES GEOMETRY		Distance , midpoint, division m:n, area, parallel, perpendicular, equation of straight line, locus	
LINEAR LAW		Comparison linear equation with the graph (log/non log)	
VECTOR	Resultant of Vectors	Collinear, parallel	
	Vectors in Cartesian Plane	State vectors in i and j , column vectors, parallel, collinear, unit vector	
DIFFERENTIATION	Differentiate	Direct/expand, uv , u/v , find the value of the diff , rate , small change, minimum/maximum	
INTEGRATION		How to integrate, properties of integration, area, volume	
CIRCULAR MEASURE		Find the angle (SOH CAH TOA) , arc length (perimeter), area , area of segment	
TRIGO		Equation , ratio (triangle)	
STAT		Mean, mod, median (formula) , Q_1 , Q_3 , IR , variance, standard deviation , effect of +/- or \times/\div	
PERMUTATIONS & COMBINATIONS		Permutations and Combinations	
PROBABILITY		Simple Probability	
PROBABILITY DISTRIBUTIONS		Binomial : find the probability , $\mu = np$, $\sigma^2 = npq$ Normal : find the probability , standard score , $z = \frac{X - \mu}{\sigma}$. find variable if the probability given.	

Paper 2

Topic	Subtopic	Concept	Check
SECTION A			
SIMULTANEOUS EQUATION		Factorisation / using the formula	
QUADRATIC EQUATION / FUNCTION		CT ² : express to the form of $a(x+b)^2 + c$; maximum/ minimum value/points , axis of symmetry , sketch the graph, the new equation when reflected x-axis/y-axis	
PROGRESSIONS	AP , GP	n-term, sum of the terms, sum to the infinity	
STATISTICS		- Mean, variance, standard deviation using formula, - Median (Formula) , Q ₁ and Q ₃ (using formula) , IR (using formula) - Histogram (find the mod)	
TRIGONOMETRI FUNCTION		- prove - graph sine/cosine/tangent ; equation of straight line , no of solution(s)	
DIFFERENTIATION		Gradient function , turning point, equation of tangent/normal , equation of the curve by integration	
SECTION B			
LINEAR LAW		with log / without log	
INTEGRATION		Area and volume by integration	
COORDINAT GEOMETRY		Equation of straight line , parallel, perpendicular, area, midpoint, division m:n, equation of locus	
CIRCULAR MEASURE		Angle in radians (SOH CAH TOA or SOT) , arc length , perimeter and area	
VECTOR		parallel, collinear , resultant of the vectors , find the variables	
PROBABILITY DISTRIBUTIONS		Binomial and Normal	
SECTION C			
INDEX NUMBER		Index, composite index , find the price using the index , “three years case”	
SOLUTION OF TRIANGLE		sine rule, cosine rule, area , ambiguous case	
LINEAR PROGRAMMING		Inequalities, graph, maximum/minimum	

INGAT ADD , INGAT A+

Answer all questions
Jawab semua soalan

1. Diagram 1 shows the graph of the function $y : \rightarrow 1 + \frac{m}{x}$, where m is a constant.

Rajah 1 menunjukkan graf bagi fungsi $y : \rightarrow 1 + \frac{m}{x}$, dengan m ialah pemalar.

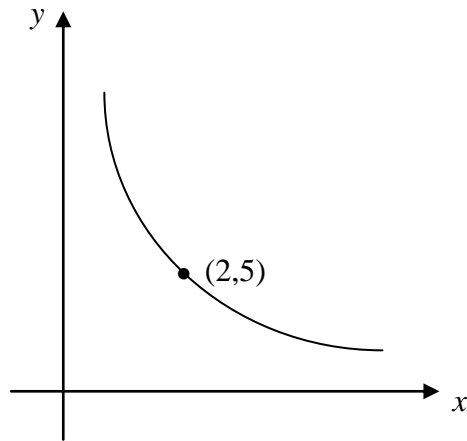

Diagram 1 /Rajah 1

Find the value of m .

Cari nilai m .

[2 marks]

Answer/Jawapan:

2. The function f is defined by $f(x) = 2x + 1$ and $fg(x) = 6x + 5$, find $g^{-1}(x)$.

Fungsi f ditakrifkan oleh $f(x) = 2x + 1$ dan $fg(x) = 6x + 5$, cari $g^{-1}(x)$.

[3 marks]

Answer/Jawapan :

3. Given the function $h : x \rightarrow ax - b$, where a and b are positive constants and the composite function

$$h^2 : x \rightarrow \frac{x - 12}{4}. \text{ Find the values of } a \text{ and } b.$$

Diberi fungsi $h : x \rightarrow ax - b$, dengan a dan b ialah pemalar positif dan fungsi gubahan

$$h^2 : x \rightarrow \frac{x - 12}{4}. \text{ Cari nilai } a \text{ dan nilai } b.$$

[3 marks]

Answer/Jawapan:

-
4. Given that the roots of the quadratic equation $x^2 - hx + 8 = 0$ are p and $2p$, find the values of h .

Diberi punca-punca persamaan kuadratik $x^2 - hx + 8 = 0$ ialah p dan $2p$, cari nilai-nilai h .

[3 marks]

Answer/Jawapan :

5. Diagram 5 shows the graph of a quadratic function $y = f(x)$. The straight line $y = -16$ is a tangent to the curve.

Rajah 5 menunjukkan graf fungsi kuadratik $y = f(x)$. Garis lurus $y = -16$ ialah tangen kepada lengkung.

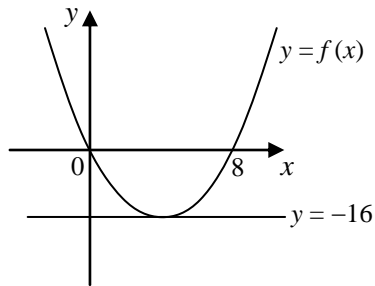

Diagram 5 / Rajah 5

- (a) Express $f(x)$ in the form $(x + b)^2 + c$, where b and c are constant.

Ungkapkan $f(x)$ dalam bentuk $(x + b)^2 + c$, dengan keadaan b dan c adalah pemalar.

- (b) The curve, $y = f(x)$ is reflected to the y -axis. State the function of the graph.

Lengkung $y = f(x)$ dipantulkan pada paksi- y . Nyatakan fungsi bagi graf ini.

[3 marks]

Answer/Jawapan :

6. Given that the function of the graph is $f(x) = 2x^2 - 4x + k$.
Find the range of k if the graph does not intersect with x-axis .
*Diberi fungsi suatu grafialah $f(x) = 2x^2 - 4x + k$.
Carikan julat nilai k jika graf itu tidak memotong paksi-x.*

[3 marks]

Answer/Jawapan :

-
7. Given that $8=7^x$ and $7=2^{2y}$., find the value of xy .
Diberi $8=7^x$ dan $7=2^{2y}$., cari nilai bagi xy .

[3 marks]

Answer/Jawapan :

8. Diagram 8 show a new motorcycle which it prize less than RM5000. After n years, the value of a new motorcycle is given by $\text{RM}4700 \left(\frac{8}{9}\right)^n$.

Rajah 8 menunjukkan sebuah motorsikal baru berharga kurang dari RM5000. Selepas n tahun, harga sebuah motosikal baru diberikan oleh $\text{RM}4700 \left(\frac{8}{9}\right)^n$.



Diagram 8 / Rajah 8

Calculate the number of years it takes for the value of motorcycle to be less than RM1000 for the first time.

Hitung bilangan tahun yang dilalui supaya harga motosikal tersebut adalah buat pertama kalinya kurang daripada RM1000

[4 marks]

Answer/Jawapan :

9. The first three terms of an arithmetic progression are $m - 3$, $m + 3$, $2m + 2$.

Tiga sebutan pertama suatu jangjang aritmetik adalah $m - 3$, $m + 3$, $2m + 2$.

Find / Cari

(a) the value of m ,

nilai m ,

(b) the three consecutive terms of these progression such that the sum is 282.

tiga sebutan yang berturutan bagi jangjang ini yang mana jumlahnya adalah 282.

[3 marks]

Answer/Jawapan :

10. In a geometric progression, the first term is 81 and the fourth term is 24.

Dalam suatu jangjang geometri, sebutan pertama ialah 81 dan sebutan keempat ialah 24.

Find the sum of infinity.

Cari hasil tambah sehingga ketakterhinggaan.

[4 marks]

Answer/Jawapan :

11. Diagram 12 shows part the graph $\log_{10}y$ against $\log_{10}x$. The value of x and y are related by the equation $y = \frac{x^2}{100}$.

Rajah 12 menunjukkan sebahagian graf $\log_{10}y$ melawan $\log_{10}x$. Nilai x dan y dihubungkan oleh persamaan $y = \frac{x^2}{100}$

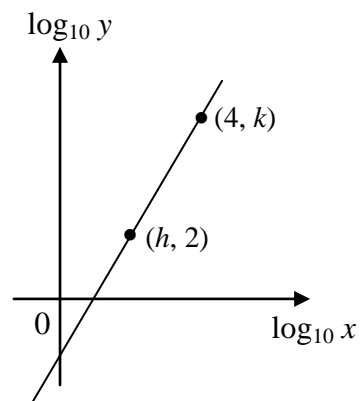

Diagram 12 / Rajah 12

Find the value of k and h .

Cari nilai k dan nilai h .

[4 marks]

Answer/Jawapan :

12. Three points have coordinates $A(2, 1)$, $B(t,5)$ and $C(6, 2)$, find the value of t if
Tiga titik mempunyai koordinat $A(2, 1)$, $B(t,5)$ dan $C(6, 2)$, cari nilai t jika

(a) AB is perpendicular to AC
 AB adalah berserenjang dengan AC

(b) the area of triangle ABC is 6 unit^2 .
luas segitiga ABC ialah 6 unit^2 .

[4 marks]

Answer/Jawapan :

13. Given that $\sin 135^\circ = \sqrt{1-y^2}$ and $\cos 60^\circ = \sqrt{1-x^2}$. Find in terms of x and/or y

Diberi $\sin 135^\circ = \sqrt{1-y^2}$ dan $\cos 60^\circ = \sqrt{1-x^2}$. Cari dalam sebutan x dan/atau y

(a) $\cos 67.5^\circ$,

kos 67.5°

(b) $\sin 120^\circ$

[3 marks]

Answer/Jawapan :

14. Solve the equation $\cot x + 2 \cos x = 0$ for $0^\circ \leq x \leq 360^\circ$.

Selesaikan persamaan $\cot x + 2 \cos x = 0$ bagi $0^\circ \leq x \leq 360^\circ$.

[3 marks]

Answer/Jawapan :

15. Given that $\vec{AB} = \begin{pmatrix} -5 \\ m \end{pmatrix}$ and $\vec{CD} = \begin{pmatrix} -2 \\ k \end{pmatrix}$, find

Diberi $\vec{AB} = \begin{pmatrix} -5 \\ m \end{pmatrix}$ dan $\vec{CD} = \begin{pmatrix} -2 \\ k \end{pmatrix}$, cari

(a) the value of m , if unit vector in the direction of \vec{AB} is $-\frac{5}{13}\vec{i} + \frac{12}{13}\vec{j}$

nilai m , jika vektor unit dalam arah \vec{AB} ialah $-\frac{5}{13}\vec{i} + \frac{12}{13}\vec{j}$

(b) the value of k , if \vec{AB} is parallel to \vec{CD} .

nilai k , jika \vec{AB} selari dengan \vec{CD} .

[3 marks]

Answer/Jawapan :

16. Given $\underline{p} = \begin{pmatrix} 12 \\ -5 \end{pmatrix}$ and $\underline{q} = \begin{pmatrix} k+1 \\ 3 \end{pmatrix}$, find the value of k such that

Diberi $\underline{p} = \begin{pmatrix} 12 \\ -5 \end{pmatrix}$ dan $\underline{q} = \begin{pmatrix} k+1 \\ 2 \end{pmatrix}$, cari nilai k dengan keadaan

(a) $|2\underline{q} + \underline{p}| = \sqrt{17}$

(b) $\underline{p} + \underline{q}$ is parallel to the y -axis.

$\underline{p} + \underline{q}$ adalah selari dengan paksi- y .

[4 marks]

Answer/Jawapan :

17. Given that the gradient of the curve $y = 2x - \frac{h}{x}$ at the point where $x = 2$ is 3.

Diberi kecerunan lengkung $y = 2x - \frac{h}{x}$ pada suatu titik ketika $x = 2$ ialah 3.

Find / Cari

(a) the value of h ,
nilai h ,

(b) the equation of the normal to the curve at the point where $x = 2$.
persamaan normal kepada lengkung pada $x = 2$.

[4 marks]

Answer/Jawapan :

18. Diagram 19 shows a semicircle RPQ with centre O and diameter 10 cm.
Rajah 19 menunjukkan semibulatan RPQ berpusat O dengan diameter 10 cm.

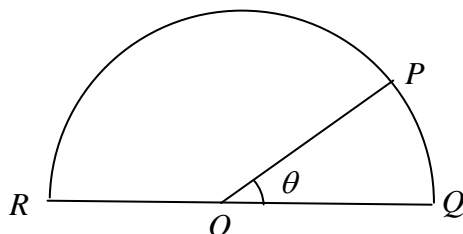

Diagram 19 / Rajah 19

Given the length of arc ROP is equal with the perimeter of sector POQ .

Diberi panjang lengkok ROP adalah sama dengan perimeter sektor POQ .

Find the value of θ in radians.

Cari nilai θ dalam radian.

[3 marks]

Answer/Jawapan :

19. Given that $y = f(x)$ and $\frac{d^2y}{dx^2} = 4 - x^2$. Find the range of values of x such that y has a maximum value .

Diberi $y = f(x)$ dan $\frac{d^2y}{dx^2} = 4 - x^2$. Cari julat nilai-nilai x sedemikian hingga y mempunyai nilai maksimum.

[3 marks]

Answer/Jawapan :

20. Diagram 20 shows the curve $y = -3x^2$.

Rajah 20 menunjukkan suatu lengkung $y = -3x^2$.

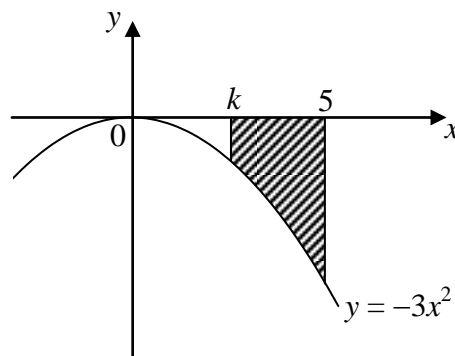

Diagram 20 / Rajah 20

Find the value of k if the area of the shaded region is 117 unit^2 .

Cari nilai bagi k jika luas kawasan berlorek ialah 117 unit^2 .

[3 marks]

Answer/Jawapan :

21. The mean and standard deviation of 7 numbers are 5 and 3 respectively.

Min dan sisihan piawai bagi 7 nombor masing-masing ialah 5 dan 3.

Calculate / *Hitung*

(a) the sum of the square of the numbers,

hasil tambah kuasa dua nombor-nombor itu,

(b) the new value of the variance if every number is multiplied by 2 and then 5 is added to it.

nilai baru bagi varians jika setiap nombor itu didarab dengan 2 dan ditambah 5.

[3 marks]

Answer/Jawapan :

22. A team of 5 invigilators are to be selected randomly from 5 female and 8 male teachers.

Find the number of ways that the team can be formed if

Sebuah pasukan 5 orang pengawas peperiksaan hendak dipilih secara rawak daripada

5 guru perempuan dan 8 guru lelaki. Cari bilangan cara pasukan tersebut boleh

dibentuk jika

(a) there are no restrictions,

tiada syarat diberi,

(b) more male teacher than female teacher in the team.

guru lelaki lebih ramai dari guru perempuan.

[3 marks]

Answer/Jawapan :

23. In a shooting training, the probability to hit the target is p .

Dalam satu latihan menembak, kebarangkalian mengenai sasaran ialah p .

Find n , the number of firing needed and the value of p , so that the success mean and variance is 30 and 20 respectively.

Cari bilangan tembakan yang diperlukan, n dan nilai p , supaya min dan varians kejayaan masing-masing ialah 30 dan 20.

[3 marks]

Answer/Jawapan :

24. How many 4-digit even numbers can be formed from the digits 1, 3, 4, 7 and 8 without repeating.

Berapakah bilangan nombor genap 4 digit yang boleh dibentuk daripada digit 1, 3, 4, 7 dan 8 tanpa ulangan.

[3 marks]

Answer/Jawapan :

25. Diagram 25 shows the standard normal distribution graph.

Rajah 25 menunjukkan graf taburan normal piawai.

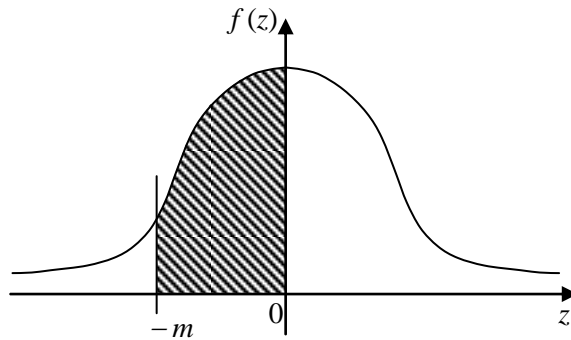

Diagram 25 / Rajah 25

The probability represented by the area of the shaded region is 0.3577.
Kebarangkalian yang diwakili oleh luas kawasan berlorek ialah 0.3577.

Find / *Cari*

- (a) $P(z < m)$
- (b) the value of m .
nilai m .

[3 marks]

Answer/Jawapan :

PANDUAN JAWAPAN KERTAS 1 SET 1

1	$m = 8$	14	$90^\circ ; 210^\circ ; 270^\circ ; 330^\circ$
2	$g(x) = \frac{x-2}{3}$	15	(a) $m = 12$ (b) $k = \frac{24}{5}$
3	$a = 0.5 ; b = 2$	16	(a) $k = -5 ; -9$ (b) $k = -13$
4	$h = \pm 6$	17	(a) $h = 4$ (b) $3y = -x + 8$
5	(a) $f(x) = (x-4)^2 - 16$ (b) $f(x) = (x+4)^2 - 16$	18	0.571
6	$k > 2$	19	$x < -2 ; x > 2$
7	$xy = 1.5$	20	$k = 2$
8	$n = 14$	21	(a) 238 (b) 36
9	(a) $m = 7$ (b) 88 , 94 , 100	22	(a) 1287 (b) 966
10	243	23	$p = \frac{1}{3} ; n = 90$
11	$k = 6 ; h = 2$	24	48
12	(a) $t = 1$ (b) 6 ; 30	25	(a) 0.8577 (b) $m = 1.07$
13	(a) $\sqrt{\frac{1-y}{2}}$ (b) $2x\sqrt{1-x^2}$		

SET 1 PAPER 2

Section A

1. Solve the simultaneous equations $y - 2x + 1 = 0$ and $4x^2 + 3y^2 - 2xy = 7$. Give your answers correct to three decimal places.

Selesaikan persamaan serentak $y - 2x + 1 = 0$ dan $4x^2 + 3y^2 - 2xy = 7$. Berikan jawapan kepada 3 tempat perpuluhan.

[5 marks]

2. a) Prove that $\tan^2 x + 2 \cos^2 x - \sec^2 x = \cos 2x$

Tunjukkan bahawa $\tan^2 x + 2 \cos^2 x - \sec^2 x = \cos 2x$

- b) (i) Sketch the graph of $y = 3 \cos 2x - 1$ for $0 \leq x \leq \frac{3}{2} \pi$

Lakarkan graf $y = 3 \cos 2x - 1$ untuk $0 \leq x \leq \frac{3}{2} \pi$

- (ii) Hence, using the same axes, sketch a suitable graph to find the number of solutions.

Seterusnya, dengan menggunakan paksi yang sama, lakarkan graf yang sesuai untuk mencari bilangan penyelesaian.

[7 marks]

3. The gradient function of a curve which passes through the point A (2,1) is $3x^2 + 2x - 5$.

Fungsi kecerunan satu lengkung yang melalui titik A (2 , 1) ialah $3x^2 + 2x - 5$.

- a) Find the equation of normal at point A.

Cari persamaan normal di titik A

- b) Find the coordinates of the turning points of the curve and determine whether each of the turning points is a maximum or a minimum point.

Carikan koordinat titik- titik pusingan bagi lengkung itu dan tentukan sama ada setiap titik pusingan itu titik maksimum atau titik minimum.

- c) Find the equation of the curve.

Cari persamaan bagi lengkung itu.

[8 marks]

4. Diagram 4 shows, a histogram which represents the distribution of the scores obtained by 40 students in a quiz.

Rajah 4 menunjukkan sebuah histogram yang mewakili taburan skor bagi 40 orang murid dalam satu kuiz.

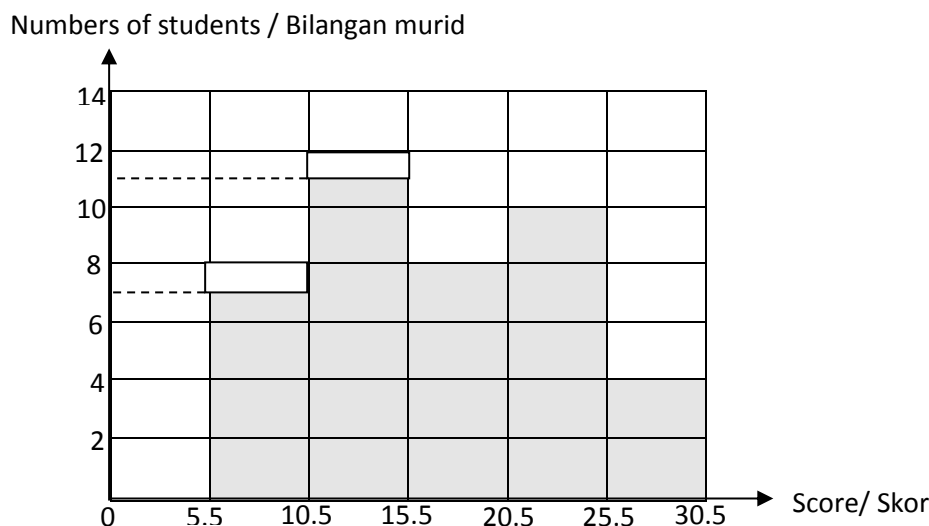

- a) Without using an ogive, calculate interquartile range.
Tanpa menggunakan ogif, hitungkan julat antara kuartil,
- b) Calculate the standard deviation of the distribution.
Hitungkan sisihan piawai bagi taburan skor itu.

[6 marks]

5. Mr Khairul and Mr Muthu starts to save money at the same time.

Encik Khairul dan Encik Muthu mula menyimpan duit pada masa yang sama.

- a) Mr Khairul saves RM p in the first month and his saving increases constantly by RM q every subsequent month. He saves RM 205 in the 8th month and the total saving for 12 months is RM 2190. Find the value of p and of q .
Encik Khairul menyimpan RM p dalam bulan pertama dan simpanannya meningkat secara malar sebanyak RM q setiap bulan berikutnya. Dia menyimpan RM 205 pada bulan ke – 8 dan jumlah simpanan untuk 12 bulan ialah RM 2190. Carikan nilai p dan nilai q .
- b) Mr Muthu saves RM 150 in the first month and his saving increases constantly by RM 10 every subsequent month. Find the value of n when both of them save the same amount of money in n^{th} month.
Muthu menyimpan RM 150 dalam bulan pertama dan simpanannya meningkat secara malar sebanyak RM 10 setiap bulan berikutnya. Carikan nilai n apabila kedua-duanya menyimpan jumlah wang yang sama pada bulan ke – n .

[6 marks]

6. Diagram 6 shows, $\angle ABC = 90^\circ$ and the equation of straight line BC is $3y - 2x + 21 = 0$.
Rajah 6 menunjukkan $\angle ABC = 90^\circ$ dan persamaan garis lurus BC ialah $3y - 2x + 21 = 0$.

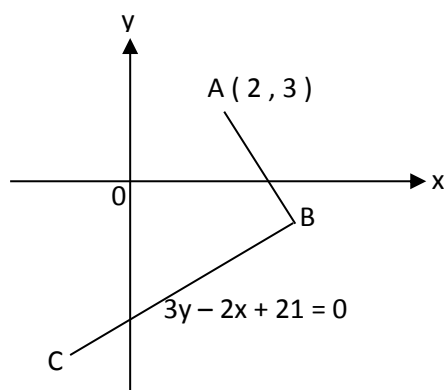

- a) Find/ Carikan
- (i) the equation of straight line AB
Persamaan garis lurus AB
 - (ii) the coordinates of point B
Koordinat titik B
 - (iii) the equation of perpendicular bisector of AB
Persamaan pembahagi dua sama seranjang bagi AB
- b) The straight line AB is extended to a point D such that $AB : BD = 2 : 3$. Find the coordinate of D.
*Garis lurus AB diperpanjangkan kepada titik D yang mana $AB : BD = 2 : 3$.
 Hitungkan koordinat titik D.*

[8 marks]

Section B

7. Table 7 shows, the values of two variables, x and y , obtained from an experiment. The variables x and y are related by the equation $y = Ca^{-x}$, where a and C are constants. One of the values of y is incorrect.
Jadual 7 menunjukkan nilai-nilai bagi dua pemboleh ubah, x dan y , yang diperolehi daripada suatu eksperimen. Pemboleh ubah x dan y dihubungkan oleh persamaan $y = Ca^{-x}$, dengan keadaan a dan C ialah pemalar. Salah satu nilai y adalah tidak tepat.

x	1	2	3	4	5	6	7
y	56.2	31.6	25.1	9.54	5.62	3.35	1.78

- a) Plot $\log_{10} y$ against x , using a scale of 2 cm to 1 unit on x -axis and 2 cm to 0.2 unit on $\log_{10} y$ -axis. Hence, draw the line of best fit.
Plot $\log_{10} y$ melawan x , dengan menggunakan skala 2 cm kepada 1 unit pada paksi- x dan 2 cm kepada 0.2 unit pada paksi- $\log_{10} y$.

- b) Identify the abnormal reading and estimate its correct value.
Kenal pasti bacaan abnormal itu, dan anggarkan nilai tepatnya.
- c) Use the graph in 7(a) to find
Gunakan graf di 7 (a) untuk mencari
 (i) the value of C and of a
Nilai C dan nilai a
 (ii) the value of x when y = 3
Nilai x apabila y = 3

[10 marks]

8. Diagram 8 shows a sector PQR of a circle with centre P and radius 12 cm. RSQT is a circle with centre O. The straight line PQ and PR are tangents to the circle at point Q and R respectively.
Rajah 8 menunjukkan sektor sebuah bulatan PQR berpusat P dan berjajari 12 cm. RSQT ialah suatu bulatan berpusat O. Garis lurus PQ dan PR ialah tangen kepada bulatan masing-masing di titik Q dan titik R.

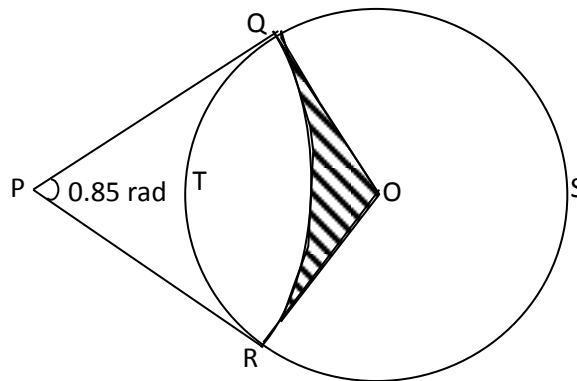
Calculate / *Hitungkan*

- a) The length, in cm of radius OQ
Panjang dalam cm, jejari OQ
- b) The length, in cm, of the arc QSR
Panjang dalam cm, panjang lengkok QSR
- c) The area, in cm^2 , of the shaded region
Luas dalam cm^2 , bagi rantau yang berlorek

[10 marks]

9. Diagram 9 shows part of the curve $y = \frac{8}{(x+1)^2}$ which passes through point A.

Rajah 9 menunjukkan sebahagian daripada lengkung $y = \frac{8}{(x+1)^2}$ yang melalui titik A

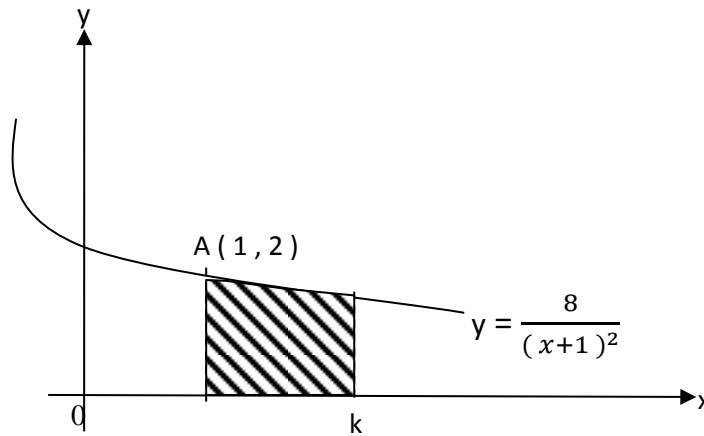

- a) Find the equation of the tangent to the curve at the point A.
Cari persamaan tangen kepada lengkung itu pada titik A
- b) If the area of the shaded region is $2\frac{2}{5}$ unit², find the value of k.
Jika luas rantau berlorek ialah $2\frac{2}{5}$ unit², cari nilai k.
- c) Calculate the volume of revolution, in terms of π , when the region bounded by the curve, the x-axis, the y-axis and the straight line $x = 1$ is rotated through 360 about the x-axis.
Hitungkan isipadu kisanan, dalam sebutan π , apabila rantau yang dibatasi oleh lengkung itu, paksi-x, paksi-y dan garis lurus $x = 1$ diputarakan melalui 360 pada paksi-x.

[10 marks]

10. a) In a house check carried out in Taman Jaya, aedes mosquitoes were found in 3 out of every 5 houses. If 10 houses in Taman Jaya are chosen at random, calculate the probability that
Dalam suatu pemeriksaan dari rumah ke rumah di Taman Jaya, nymuk aedes telah dijumpai dalam 3 daripada 5 buah rumah. Jika 10 buah rumah di Taman Jaya dipilih secara rawak, hitungkan kebarangkalian bahwa
- (i) exactly 4 houses are infested with aedes mosquitoes,
Tepat 4 buah rumah dipenuhi dengan nyamuk aedes,
- (ii) more than 2 houses are infested with aedes mosquitoes
Lebih daripada 2 buah rumah dipenuhi dengan nyamuk aedes.

- b) A school with 2000 students take part in a cross-country event. The cross-country event started at 0800 hours. Time taken for the students to finish the event is normally distributed with a mean of 40 minutes and a variance of 100 minutes².

Sebuah sekolah yang mempunyai 2000 orang murid mengambil bahagian dalam acara merentas desa. Acara merentas desa bermula jam 0800. Tempoh masa untuk murid-murid menamatkan acara adalah bertabur secara normal dengan min 40 minit dan varians 100 minit².

- (i) Find the probability of students who finished the event after 1 hour.

Cari kebarangkalian murid-murid yang menamatkan acara merentas desa selepas 1 jam.

- (ii) If 450 students finished the event in less than t minutes, find the value of t.

Jika 450 orang murid menamatkan acara itu kurang daripada t minit, carikan nilai t.

[10 marks]

11. Diagram 10 shows, a triangle POQ. P is a midpoint of BC and Q is a midpoint of AC.

Given that $\vec{AB} = \vec{u}$, $\vec{AC} = \vec{v}$ and $AR : RP = 2 : 1$.

Dalam Rajah 3, ABC ialah sebuah segitiga. P ialah titik tengah BC dan Q ialah titik tengah AC. Diberi $\vec{AB} = \vec{u}$, $\vec{AC} = \vec{v}$ dan $AR : RP = 2 : 1$.

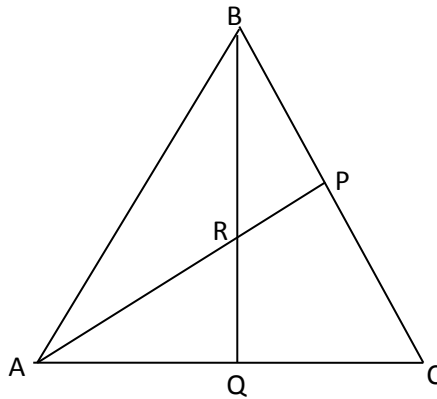

- a) Express \vec{AP} in terms of \vec{u} and/ or \vec{v}
Tuliskan AP dalam sebutan u dan / atau v
- b) If S is a midpoint of AB, shows that C, R and S is collinear.
Jika S ialah titik tengah AB, tunjukkan bahawa C, R dan S adalah segaris.
- c) Given area of ΔABC is 30 unit², find the area, in unit², ΔBPR
Diberi luas ΔABC ialah 30 unit², cari luas dalam unit², ΔBPR

[10 marks]

Section C

12. A particle moves along a straight line and passes through a fixed point O. Its velocity of the particle, $v \text{ ms}^{-1}$, is given by $v = t^2 - 7t + 10$, where t is the time, in second, after passing through O. [Assume motion to the right is positive]
Suatu jasad bergerak di sepanjang suatu garis lurus dan melalui satu titik tetap O. Halajunya $v \text{ ms}^{-1}$ diberi oleh $v = t^2 - 7t + 10$, dengan keadaan t ialah masa, dalam saat, selepas melalui O. [Anggapkan gerakan ke arah kanan sebagai positif]
- a) Find / Cari
 (i) the initial velocity of the particle
Halaju awal zarah itu,
- (ii) the range of values of t during which the particle moves to the left.
Julat nilai-nilai t apabila zarah itu bergerak ke arah kiri
- b) Hence, find the minimum velocity in ms^{-1} , of the particle.
Seterusnya, cari halaju minimum, dalam ms^{-1} zarah itu.
- c) Sketch the velocity-time graph of the motion of the particle for $0 \leq t \leq 5$.
Lakarkan graf halaju melawan masa bagi pergerakan zarah itu itu $0 \leq t \leq 5$,
- d) Calculate the total distance, in m, travelled by the particle in the first 5 seconds.
Hitung jumlah jarak, dalam m, yang dilalui oleh zarah itu dalam masa 5 saat pertama.
 [10 marks]
13. A construction company employs x semi skilled workers, y skilled-workers and z supervisors respectively at a daily rated pay of RM 40, RM 80 and RM 120 each.
 The engagement of these workers in a construction site is based on the following constrains:
Sebuah syarikat pembinaan menggaji x orang pekerja separuh mahir, y orang pekerja mahir dan z orang penyelia masing-masing dengan kadar bayaran RM 40, RM 80 dan RM 120 sehari.
- I The total number of semi-skilled and skilled workers is not less than four times of supervisors.
Jumlah bilangan pekerja separuh mahir dan pekerja mahir tidak kurang daripada empat kali bilangan penyelia.
- II The total number of semi-skilled workers, skilled-workers and supervisors is at most 110 persons,
Jumlah bilangan pekerja separuh mahir, pekerja mahir dan penyelia selebih-lebihnya 110 orang,
- III The total salary per day of all the semi-skilled workers, skilled-workers and supervisors is at least RM 3600.
Jumlah gaji sehari bagi kesemua pekerja separuh mahir, pekerja mahir dan penyelia adalah sekurang-kurangnya RM 3600.

- a) If there are 10 supervisors working on any day, write down the three inequalities in x and y that satisfy all the above constraints.

Hence, by using a scale of 2 cm to 20 workers on both axes, construct and shade the region R that satisfies all the constraints.

Jika 10 orang penyelia diambil bekerja pada sesuatu hari, tulis tiga ketaksamaan dalam x dan y yang memenuhi semua kekangan di atas.

Seterusnya, dengan menggunakan skala 2 cm kepada 20 orang pekerja pada kedua-dua paksi, bina dan lorek rantau R yang memenuhi semua kekangan di atas.

- b) Using the graph from 15(b), find

Menggunakan graf dari 13(b), cari

- (i) the minimum total daily pay if the number of semi-skilled workers is thrice the number of skilled workers.

Jumlah gaji harian yang minimum jika bilangan pekerja separuh mahir ialah tiga kali bilangan pekerja mahir.

- (ii) the maximum number of semi-skilled workers if there are 30 skilled workers working on a particular day.

Bilangan maksimum pekerja separuh mahir jika 100 orang pekerja mahir diambil bekerja pada sesuatu hari.

[10 marks]

14. Table 14 shows the prices indices, I_1 and I_2 , of three items X, Y and Z for the years 2004 dan 2006 respectively based on the year 2002.

Jadual 14 menunjukkan indeks harga I_1 dan I_2 bagi tiga barang X, Y dan Z masing-masing pada tahun 2004 dan 2006 berasaskan tahun 2002.

Item Barang	Price index / Indeks harga		Weightage Pemberat
	I_1	I_2	
X	108.0	135.0	3 - k
Y	95.0	114.0	k
Z	113.0	169.5	5

The composite index for the three items for the year 2004 based on the year 2002 is 109.5.

Indeks gubahan bagi tiga barang pada tahun 2004 berasaskan tahun 2002 ialah 109.5.

- a) Show that $k = 1$

Tunjukkan bahawa $k = 1$,

- b) Calculate the composite index for the three items for the year 2006 based on the year
Hitungkan indeks gubahan bagi tiga barang itu pada tahun 2006 berasaskan tahun

(i) 2002

(ii) 2004

- c) The total manufacturing cost of the three item X , Y and Z for the year 2004 is RM 600 000. Calculate the corresponding cost for the year 2006.
Jumlah kos penghasilan tiga barang X , Y dan Z itu pada tahun 2004 ialah RM 600 000. Hitungkan kos yang sepadan pada tahun 2006.

[10 marks]

15. Diagram 15 shows a triangle ABC
 Rajah 15 menunjukkan segitiga ABC

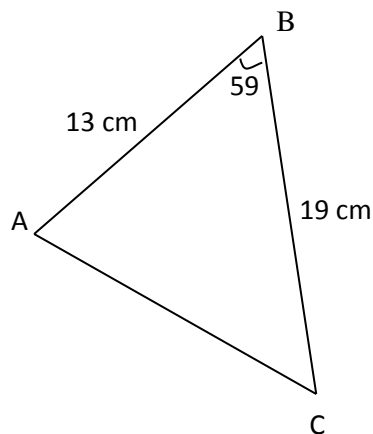

- a) Calculate the length of AC
 Hitungkan panjang AC,
- b) A quadrilateral ABCD is formed such that AC is a diagonal, $\angle CAD = 42^\circ$ and $CD = 15$ cm. Calculate the two possible values of $\angle ADC$.
 Sebuah sisi empat ABCD dibentuk dengan keadaan AC sebagai pepenjuruanya, $\angle CAD = 42^\circ$ dan $CD = 15$ cm. Hitungkan dua nilai yang mungkin bagi $\angle ADC$.
- c) By using the acute $\angle ADC$ from 15(b), calculate
 Dengan menggunakan sudut tirus ADC dari 15 (b) , hitungkan
- (i) the length of AD
 Panjang AD
- (ii) the area, in cm^2 of the quadrilateral ABCD
 Luas dalam cm^2 , sisi empat ABCD.

[10 marks]

PANDUAN JAWAPAN

1	$x = 1.129, -0.295$ $y = 1.258, -1.590$	9	a) $y = -2x + 4$ b) $k = 4$ c) $18\frac{2}{3} \text{ unit}^3$
2	a) Proof b) (i) Graf (ii) 3	10	a) (i) 0.1115 (ii) 0.9983 b) (i) 0.0228 (ii) $t = 32.45$
3	a) $11y = -x + 13$ b) $y = x^3 + x^2 - 5x - 1$ c) Min point (1,-4) Max point ($-5/3, 148/27$)	11	a) $AP = \frac{1}{2}u + \frac{1}{2}v$ b) Show that c) 5 unit^2
4	a) 10.64 b) 6.313	12	a) (i) $v = 10 \text{ ms}^{-1}$ (ii) $2 < t < 5$ b) -2.25 ms^{-1} c) Graf d) $79/6 \text{ m}$
5	a) $q = 15$ $p = 100$ b) $n = 11$	13	a) $x + y \geq 40$ $x + y \leq 190$ $x + 2y \geq 60$ b) (36, 12), min = RM 3600 c) 70
6	a)(i) $y = (-3/2)x + 6$ (ii) B (6 , -3) (iii) $3y = 2x - 8$ b) D (12 , -12)	14	a) Show that b) (i) 153.9 (ii) 140 c) RM 840 000.00
7	a) Graf b) $y = 17.78$ c) (i) $a = 1.745$ $c = 95.50$ (ii) $x = 6.1$	15	a) $AC = 16.60 \text{ cm}$ b) $\sphericalangle ADC = 47.77$ or 132.23 c) (i) $AD = 22.42 \text{ cm}$ (ii) 230.4 cm^2
8	a) $OQ = 5.431$ b) 21.68 cm c) 3.972 cm^2		

Answer **all** questions.

For
examiner's
use only

- 1 Diagram1 shows a function that maps set P to set Q .
Rajah 1 menunjukkan fungsi yang memeta set P ke set Q .

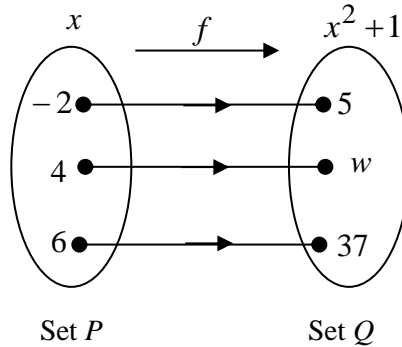

It is given that the function that maps set P to set Q is $f : x \rightarrow x^2 + 1$.

Diberi bahawa fungsi yang memeta set P ke set Q ialah $f : x \rightarrow x^2 + 1$

- (a) Find
Cari

- (i) the value of w ,
nilai w ,
- (ii) the value of $ff^{-1}(5)$.
nilai $ff^{-1}(5)$.

- (b) Write the relation in the form of ordered pairs.
Tulis hubungan ini dalam bentuk pasangan tertib.

[3 marks/markah]

Answer/Jawapan :

- (a) (i)
(ii)
(b)

1

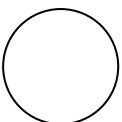
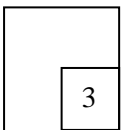

2 Given that $f : x \rightarrow h - kx$.

Diberi $f : x \rightarrow h - kx$.

Find the value of h and value of k , if $f^{-1}(14) = -4$ and $f(5) = -13$.

Cari nilai h dan nilai k , jika $f^{-1}(14) = -4$ dan $f(5) = -13$.

Answer/Jawapan :

[4 marks/markah]

For
examiner's
use only

2

4

3 Given that $g : x \rightarrow x + 3$ and $fg : x \rightarrow x^2 + 6x + 7$, find

Diberi $g : x \rightarrow x + 3$ dan $fg : x \rightarrow x^2 + 6x + 7$, cari

(a) $f(x)$,

(b) the values of a if $f(2a) = 2a$.

nilai-nilai a jika $f(2a) = 2a$.

Answer/Jawapan :

[4 marks/markah]

3

4

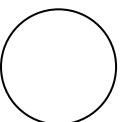

For
examiner's
use only

4

- (a) Form the quadratic equation which has the roots $\frac{2}{3}$ and $-\frac{1}{5}$.

Give your answer in the form of $ax^2 + bx + c = 0$, where a , b and c are constants.

Bentukkan persamaan kuadrat yang mempunyai punca-punca $\frac{2}{3}$ dan $x = -\frac{1}{5}$.

Beri jawapan dalam bentuk $ax^2 + bx + c = 0$, dengan keadaan a , b dan c adalah pemalar.

- (b) The quadratic equation $x(x+k) = hx - 4$ has two equal roots. Find the values of $k - h$.
Persamaan kuadrat $x(x+1) = hx - 4$ mempunyai dua punca-punca yang sama. Cari nilai-nilai bagi $k - h$.

[4 marks/markah]

Answer/ Jawapan :

(a)

(b)

4

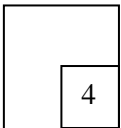

5

- Given quadratic function $f(x) = -3[(x-p)^2 + q]$ has a maximum point $R(4n, 6n^2)$.

Diberi fungsi kuadrat $f(x) = -3[(x-p)^2 + q]$ mempunyai titik maksimum. $R(4n, 6n^2)$.

Express q in terms p .

Nyatakan q dalam sebutan p .

[3 marks/markah]

5

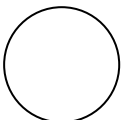
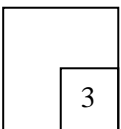

- 6 Find the range of the values of x for $(x+3)(x-1) \geq 3(x+3)$.
Cari julat nilai-nilai x bagi $(x+3)(x-1) \geq 3(x+3)$.

[3 marks/markah]

Answer/Jawapan:

For
examiner's
use only**6**

3

- 7 Solve the equation $2^{x+7} = 4 + 2^{x+6}$.
Selesaikan persamaan $2^{x+7} = 4 + 2^{x+6}$

[3 marks/markah]

Answer/Jawapan:

7

3

- 8 Solve the equation $2\log_3(x+1) = \log_3(x-1) + 2$.
Selesaikan persamaan $2\log_3(x+1) = \log_3(x-1) + 2$.

[3 marks/markah]

Answer/Jawapan :

8

3

- 9 Given $\log_5 3 = k$, if $5^{2h-1} = 15$, express h in terms of k .
Diberi $\log_5 3 = k$, jika $5^{2h-1} = 15$, ungkapkan h dalam sebutan k .

[3 marks/markah]

Answer/Jawapan :

9

3

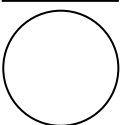

For
examiner's
use only

- 10 It is given an arithmetic progression is 66, 62, 58,, -6. Find the number of terms of this progression.

Diberi bahawa suatu jangjang aritmetik ialah 66, 62, 58,, -6. Cari bilangan sebutan dalam jangjang itu..

[2 marks/markah]

Answer/Jawapan:

10

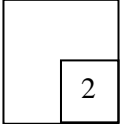

- 11 Diagram 11 shows three square tiles.

Rajah 11 menunjukkan tiga keping jubin berbentuk segiempat sama.

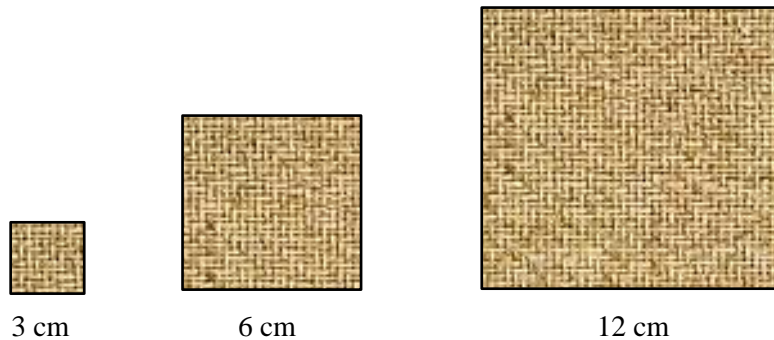

Diagram/Rajah 11

The area of the tiles form a geometric progression.

Luas jubin-jubin itu membentuk suatu jangjang geometri.

- (a) Write down the first three terms of the progression.
Tulis tiga sebutan pertama jangjang itu.
- (b) Find the total area of the first five tiles after the third tiles.
Cari jumlah luas bagi lima jubin selepas jubin yang ketiga.

[3 marks/markah]

Answer/Jawapan :

(a)

(b)

11

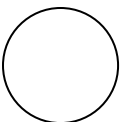
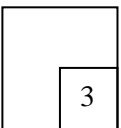

12

The variables x and y are related by the equation $y = \frac{x^{2p}}{q}$, where p and q are constants.

Diagram 12 shows a straight line graph $\log_3 y$ against $\log_3 x$

Pembolehubah x dan y dihubungkan oleh persamaan $y = \frac{x^{3p}}{q}$, dengan keadaan p dan q ialah pemalar. Rajah 12 menunjukkan graph $\log_3 y$ melawan $\log_3 x$.

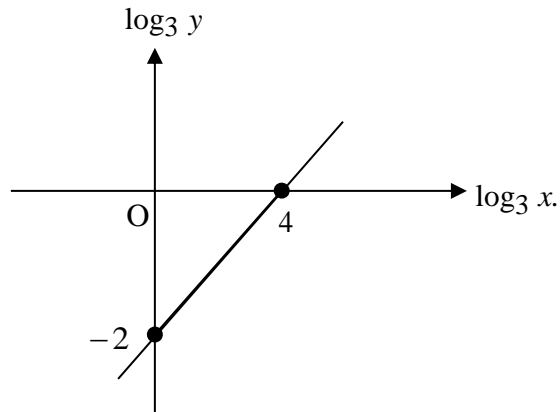

Diagram/Rajah 12

Find the value of p and of q .

Cari nilai p dan nilai q .

[4 markah/marks]

Answer/Jawapan :

*For
examiner's
use only*

12

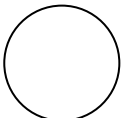
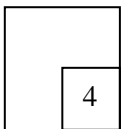

For
examiner's
use only

- 13 Diagram 13 shows a triangle PQR , where the point P lies on the y -axis.
Rajah 13 menunjukkan sebuah segitiga PQR , dengan keadaan titik P terletak pada paksi- y .

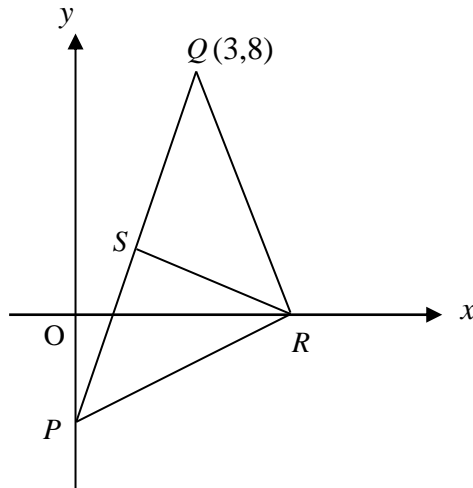

Diagram/Rajah 13

Given the equation the straight line PSQ is $y = 3x - 1$ and the equation of the straight line RS is $3y + x = 7$.

Diberi persamaan garis lurus PSQ ialah $y = 3x - 1$ dan persamaan garis lurus RS ialah $3y + x = 7$.

Find
Cari

- (a) the coordinates of point S ,
koordinat titik S ,
- (b) the ratio $PS : PQ$.
nisbah $PS : PQ$.

[4 marks/markah]

Answer/Jawapan:

(a)

(b)

13

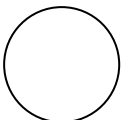
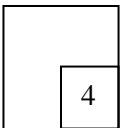

- 14 Given that $ABCD$ is a parallelogram, $\vec{BC} = i + 2j$ and $\vec{CD} = -3i - 3j$.

Diberi bahawa $ABCD$ ialah sebuah segiempat selari, $\vec{BC} = i + 2j$ dan $\vec{CD} = -3i - 3j$.

Find
Cari

- (a) \vec{AC} ,
(b) unit vector in direction of \vec{AB} .
vektor unit dalam arah \vec{AB} .

[3 marks/markah]

Answer/Jawapan :

(a)

(b)

15

3

- 15 Diagram 15 shows $\vec{OA} = x$ and $\vec{OB} = y$.

Rajah 15 menunjukkan $\vec{OA} = x$ dan $\vec{OB} = y$.

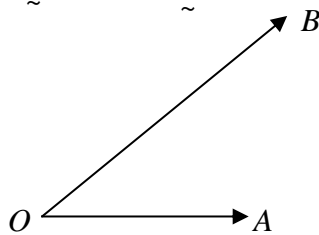

Diagram/Rajah 15

Find the value of h and k if $(h-2)x = (3h+k)y$.

Cari nilai h dan k jika $(h-2)x = (3h+k)y$.

[2 marks/markah]

Answer/Jawapan :

15

2

For
examiner's
use only

16 Given $\cot \theta = \frac{1}{\sqrt{p^2 - 1}}$ for $\pi \leq \theta \leq 2\pi$, find the value of p if $\sin \theta = \cos \theta$.

Diberi $\cot \theta = \frac{1}{\sqrt{p^2 - 1}}$ bagi $\pi \leq \theta \leq 2\pi$, cari nilai p jika $\sin \theta = \cos \theta$.

[3 marks/markah]

Answer/Jawapan :

16

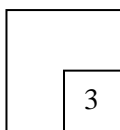

17 Solve the equation $3(\sin x - \cos x) = 2 \cos x$ for $0^\circ \leq x \leq 360^\circ$.

Selesaikan persamaan $3(\sin x - \cos x) = 2 \cos x$ bagi $0^\circ \leq x \leq 360^\circ$.

[3 marks/markah]

Answer/Jawapan :

17

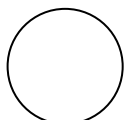
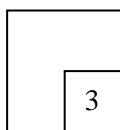

- 18 Diagram 18 shows a position of a simple pendulum that swings from P to Q .
Rajah 18 menunjukkan kedudukan suatu bandul ringkas yang berayun dari P ke Q .

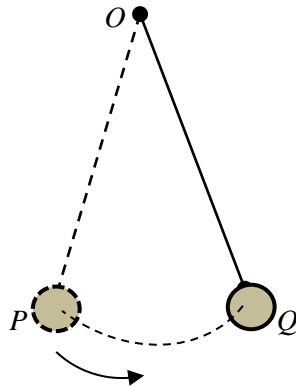

Diagram/Rajah 18

If $OP = 20$ cm and the length of the arc PQ is 15.6 cm, find
Jika $OP = 20$ cm dan panjang lengkok PQ ialah 15.6 cm, cari

- (a) θ dalam darjah, ,
 θ in degrees ,,
- (b) the area, in cm^2 , of the region covered by the pendulum.
luas, dalam cm^2 , rantau yang dilalui oleh bandul.

[4 marks/markah]

Answer/Jawapan :

*For
 examiner's
 use only*

18

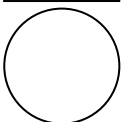
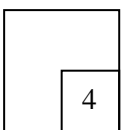

For
examiner's
use only

19 Given $\frac{d^2y}{dx^2} = 4x^3 + 1$. When $x = -1$, $y = \frac{1}{2}$ and $\frac{dy}{dx} = 3$, express y in terms of x .

Diberi $\frac{d^2y}{dx^2} = 4x^3 + 1$. Bila $x = -1$, $y = \frac{1}{2}$ dan $\frac{dy}{dx} = 3$, ungkapkan y dalam sebutan x .

[3 marks/markah]

Answer/Jawapan:

19

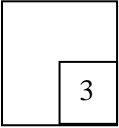

20 Two variables, p and q , are related by the equation $p = 8q + \frac{2}{q}$.

Dua pemboleh ubah p dan q , dihubungkan oleh persamaan $p = 8q + \frac{2}{q}$.

(a) Calculate the maximum value of p .
Hitung nilai maksimum bagi p .

(b) If q changes from 3 to 3.01 cm, find the small change in p .
Jika q berubah dari 3 kepada 3.01 cm, cari perubahan kecil p .

[4 marks/markah]

Answer/Jawapan :

20

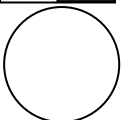
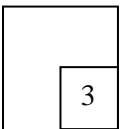

21 Given $\frac{d}{dx}\left(\frac{x^2}{x+1}\right) = \frac{3}{5}g(x)$, find the value of $\int_0^2 [x - g(x)] dx$.

Diberi $\frac{d}{dx}\left(\frac{x^2}{x+1}\right) = \frac{3}{5}g(x)$, cari nilai bagi $\int_0^2 [x - g(x)] dx$.

[3 marks/markah]

Answer/Jawapan :

For
examiner's
use only

21

3

- 22 A set of numbers $x_1, x_2, x_3, x_4, \dots, x_n$ has a median of 5 and a standard deviation of 2.
Satu set nombor-nombor, $x_1, x_2, x_3, x_4, \dots, x_n$ mempunyai median 5 dan sisihan piawai 2.

Find the median and the variance for the set of numbers

$$6x_1 + 1, 6x_2 + 1, 6x_3 + 1, \dots, 6x_n + 1$$

Cari median dan varians bagi nombor-nombor $6x_1 + 1, 6x_2 + 1, 6x_3 + 1, \dots, 6x_n + 1$.

[2 marks/markah]

Answer /Jawapan:

- 23 A box contains 6 blue marbles and $n+1$ red marbles. If a marble is picked randomly from the box, the probability of getting red marbles is 0.6. Find the value of n .
Sebuah kotak mengandungi 6 biji guli biru dan $n+1$ biji guli merah. Jika sebiji guli dikeluarkan secara rawak daripada kotak itu, kebarangkalian mendapatkan guli merah ialah 0.6. Cari nilai n .

[3 marks/markah]

Answer/Jawapan:

24

3

For
examiner's
use only

- 24 The probability that Shahrul scored a goal from a penalty kick in a soccer practice is t . Shahrul attempts n penalty kicks and the number of goals is recorded. Given that the mean and the standard deviation of the number of goals are 60 and 6 respectively, find the value of t and of n .

Kebarangkalian Shahrul menjaringkan gol bagi satu tendangan penalty dalam satu latihan bola sepak ialah t . Shahrul melakukan n tendangan penalty dan bilangan jaringan gol dicatat. Diberi min dan sisihan piawai bagi bilangan jaringan gol masing-masing ialah 60 dan 6, cari nilai t dan nilai n .

[3 marks/markah]

Answer/Jawapan :

24

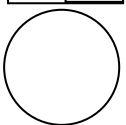
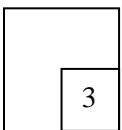

- 25 Diagram 25 shows a graph of probability distribution for the continuous variable x which is normally distributed with the standard deviation 3.5. The graph is symmetry at the straight line PQ .

*For
examiner's
use only*

Rajah 25 menunjukkan graf taburan kebarangkalian bagi pembolehubah rawak selanjar x yang bertaburan secara normal dengan sisihan piawai 3.5. Graf adalah bersimetri pada garis lurus PQ

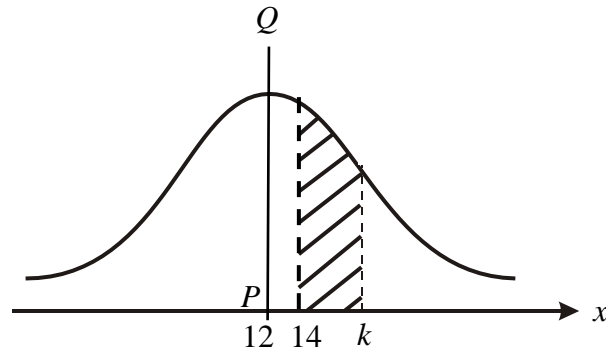

Diagram/Rajah 25

If the standard score z at $x=k$ is 1.5, find
Jika skor piawai z pada $x=k$ ialah 1.5, cari

- (a) the value of k ,
nilai k ,
- (b) $P(14 < x < k)$

[4 marks/markah]

Answer/Jawapan :

25

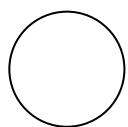
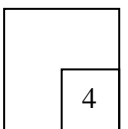

KERTAS SOALAN TAMAT

PANDUAN JAWAPAN KERTAS 1 SET 2

1	(a) 17 (b) 5 (c) $\{(-2,5),(4,17),(6,37)\}$	2	$h=2$, $k=3$
3	(a) x^2-2 (b) $a=-\frac{1}{2}$, $a=1$	4	(a) $15x^2-7x-2=0$ (b) -4 , 4
5	$q=-\frac{p^2}{8}$	6	$x \leq -3$, $x \geq 4$
7	-4	8	2 , 5
9	$h=\frac{k+2}{2}$	10	19
11	(a) 9,36,144 (b) 196 416	12	$p=\frac{1}{4}$, $q=9$
13	(a) (1,2) (b) 1:3	14	(a) $4i+5j$ (b) $\frac{3i+3j}{\sqrt{18}}$ ~ ~
15	$h=2$, $k=-6$	16	-1.414 , 1.414
17	59.04^o , 239.04^o	18	(a) 44.68^o (b) 156
19	$y=\frac{x^5}{5}+\frac{x^2}{2}+3x+\frac{16}{5}$	20	(a) 8 (b) $\frac{7}{90}$
21	$-\frac{2}{9}$	22	(a) 31 (b) 144
23	8	24	$n=150$, $t=0.4$
25	(a) 17.25 (b) 0.2172		

1. Given that $(3h, 2k)$ is a solution to the simultaneous equations $\frac{3}{x} + \frac{2}{3y} = 1$ and $2x - 4y - 1 = 0$, find the possible values of h and the corresponding values of k . [6 marks]

Diberi bahawa $(3h, 2k)$ ialah penyelesaian persamaan serentak $\frac{3}{x} + \frac{2}{3y} = 1$ dan $2x - 4y - 1 = 0$, cari nilai-nilai yang mungkin bagi h dan nilai-nilai yang sepadan bagi k . [6 markah]

2. The function $f(x) = -x^2 + 4mx - 5m^2 - 1$, has a maximum value of $-n^2 - 2m$, where m and n are constants.

Fungsi $f(x) = -x^2 + 4mx - 5m^2 - 1$, mempunyai nilai maksimum $-n^2 - 2m$, di mana m dan n adalah pemalar.

- (a) By completing the square, show that $n = m - 1$. [4 marks]
Dengan menggunakan penyempurnaan kuasa dua, tunjukkan bahawa $n = m - 1$. [4 markah]

- (b) Hence, or otherwise, find the value of m and of n if the graph of the function is symmetrical about $x = n^2 - 1$, such that $m \neq 0$. [4 marks]

Seterusnya, atau dengan cara lain, cari nilai bagi m dan n jika graf bagi fungsi itu simetri pada $x = n^2 - 1$ dengan keadaan $m \neq 0$. [4 markah]

3. Diagram 3, shows a hemispherical container of radius 12 cm. It contains water and it is placed under the hot sun. Due to evaporation, the water level, h cm, is decreasing at the rate of 0.06 cms^{-1} .

Rajah 3, menunjukkan bekas berbentuk hemisfera dengan jejari 12 cm. Bekas itu berisi air dan ditempatkan di bawah panas matahari. Disebabkan proses pemeruawapan, paras air, h cm, menyusut pada kadar 0.06 cms^{-1} .

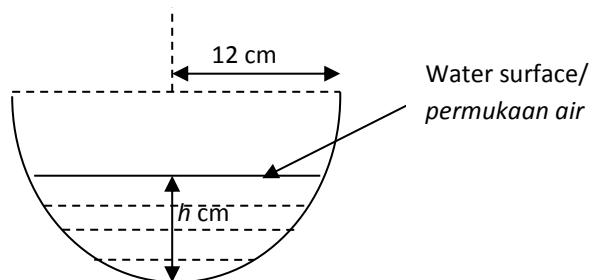

Diagram/Rajah 3

- (a) Show that the area of the water surface, $A \text{ cm}^2$, is given by $A = \pi(24h - h^2)$. [3 marks]
Tunjukkan bahawa luas permukaan air, $A \text{ cm}^2$, diberi oleh $A = \pi(24h - h^2)$. [3 markah]

- (b) Calculate the rate of decrease of the area of the water surface at the instant $h = 9 \text{ cm}$. [3 marks]
Hitung kadar susutan luas permukaan air pada ketika $h = 9 \text{ cm}$ [3 markah]

4. Diagram 4, shows a straight line PQ which is perpendicular to the straight line PR at point P . Point $T(1, 2)$ lies on the straight line PQ .

Rajah 4, menunjukkan satu garis lurus PQ yang berserenjang dengan garis lurus PR pada titik P . Titik $T(1, 2)$ terletak pada garis lurus PQ .

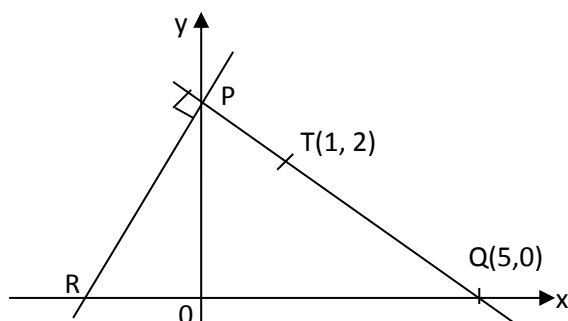

Diagram/Rajah 4

- (a) Find the coordinates of point P and point R . [3 marks]
Cari koordinat bagi titik P dan titik R . [3 markah]
- (b) Point M is a moving point such that its distance from point T is always 2 units.
Titik M adalah titik bergerak di mana jaraknya daripada titik T sentiasa 2 unit.
- (i) Find the equation of the locus of point M .
Cari persamaan lokus bagi titik M .
- (ii) Determine whether the locus of point M touches or intersects or does not meet the x -axis.
Tentukan sama ada lokus bagi titik M menyentuh atau menyalang atau tidak bertemu paksi- x . [4 marks/markah]
5. Diagram 5, shows a few sectors of concentric circles with centre O . The angle subtended at the centre of the circle is $\frac{\pi}{3}$ radians. The arcs of the circles increase by π cm successively.

Rajah 5, menunjukkan beberapa sektor bagi bulatan sepusat berpusat di O . Sudut yang tercangkum di pusat bulatan ialah $\frac{\pi}{3}$ radian. Lengkuk bagi bulatan itu bertambah sebanyak π cm secara berturutan.

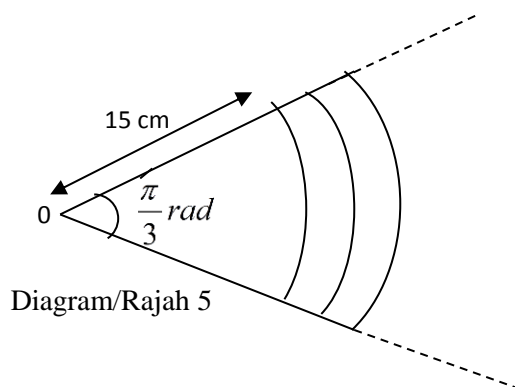

Diagram/Rajah 5

- (a) Find the sum of the lengths of arcs of the first 15 sectors, in terms of π . [3 marks]
Cari jumlah panjang lengkuk bagi 15 sektor yang pertama, dalam sebutan π . [3 markah]
- (b) Determine which sector that has the area of 294π cm². [4 marks]
Tentukan sector yang manakah yang mempunyai luas sektor 294π cm². [4 markah]

6. (a) Sketch the graph of $y = -\tan \frac{3}{2}x$ for $0 \leq x \leq \pi$. [3 marks]

Lakar graf bagi $y = -\tan \frac{3}{2}x$ bagi $0 \leq x \leq \pi$. [3 markah]

- (b) Hence, using the same axes, sketch a suitable straight line to find the number of solutions to the equation $\pi \tan \frac{3}{2}x + 2x = 0$ for $0 \leq x \leq \pi$. [3 marks]

Seterusnya, dengan menggunakan paksi yang sama, lakar satu garis lurus yang sesuai untuk mencari bilangan penyelesaian bagi persamaan $\pi \tan \frac{3}{2}x + 2x = 0$ for $0 \leq x \leq \pi$. [3 markah]

SECTION B

7. (a) 3% of the car batteries produced by a factory do not meet the standard requirement. Find the minimum number of batteries that have to be tested so that the probability that at least one battery does not meet the standard requirement is greater than 0.95. [5 marks]

3% daripada bateri kereta yang dikeluarkan oleh sebuah kilang didapati tidak mencapai tahap keperluan piawai. Cari bilangan minimum bateri yang perlu diuji supaya kebarangkalian sekurang-kurangnya satu bateri tidak mencapai keperluan piawai adalah lebih besar daripada 0.95.

[5 markah]

- (b) The diameters of table-tennis balls produced by a factory follow a normal distribution with a mean of μ mm and a standard deviation of σ mm. It is given that 22.66% of the balls have diameters of more than 41.5 mm and 10.56% of the balls have diameters of less than 37.5 mm. Find the value of μ and of σ .

Diameter bagi bola pingpong yang dikeluarkan oleh sebuah kilang adalah mengikut taburan normal dengan min μ mm dan sisihan piawai σ mm. Diberi bahawa 22.66% daripada bola itu mempunyai diameter melebihi 41.5 mm dan 10.56% daripada bola itu mempunyai diameter kurang daripada 37.5 mm. Cari nilai bagi μ dan σ .

[5 Marks/markah]

- 8.(a) Table 8, shows the distribution of profits obtained by 40 stall owners at a night market.

Jadual 8, menunjukkan taburan bagi keuntungan yang diperolehi oleh tuan punya kepada 40 gerai di suatu pasar malam.

Profit/ Keuntungan (RM)	Frequency/ Frekuensi
30 – 39	m
40 – 49	13
50 – 59	5
60 – 69	n
70 – 79	7

Table/Jadual 8

Given that the third quartile profit is RM67, find the value of m and of n . [5 marks]

Diberi bahawa kuartil ketiga keuntungan ialah RM67, cari nilai bagi m dan n . [5 markah]

- (b) The set of data 2, 3, $x + 2$, 6, 7, $2x + 2$ and 11 has a mean of p . When each number is multiplied by 2 and then 3 is added to each product, the new mean is 15 and the new standard deviation is $t\sqrt{2}$. Find the value of p , of x and of t . [5 marks]

Set data 2, 3, $x + 2$, 6, 7, $2x + 2$ dan 11 mempunyai min p . Apabila setiap nombor itu didarab dengan 2 dan kemudian ditambah dengan 3, min baru ialah 15 dan sisihan piawai baru ialah $t\sqrt{2}$. Cari nilai bagi p , x dan t . [5 markah]

9. Diagram 9, shows a circle with centre O and a radius of 12 cm.

Rajah 9, menunjukkan sebuah bulatan berpusat O dan berjajari 12 cm.

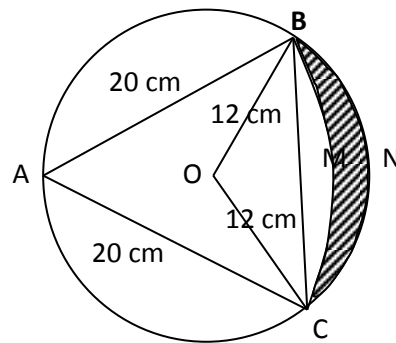

Diagram/Rajah 9

Given that $AB = AC = 20$ cm and BMC is an arc of a circle with centre A , find
Diberi $AB = AC = 20$ cm dan BMC ialah lengkok bagi sebuah bulatan berpusat A , cari

- (a) $\angle BAC$ in radians, [3 marks]
 $\angle BAC$ dalam radian [3 markah]
- (b) the length of the major arc BAC , [3 marks]
 panjang lengkok major BAC [3 markah]
- (c) the area of the segment BMC and hence, calculate the area of the shaded region. [4marks]
 luas segmen BMC dan seterusnya, hitung luas rantau berlerek [4 markah]

10. Diagram 10, shows $\triangle OAB$. The straight line AP intersects the straight line OQ at R .

Diagram 10, menunjukkan $\triangle OAB$. Garis lurus AP menyalang garis lurus OQ pada R .

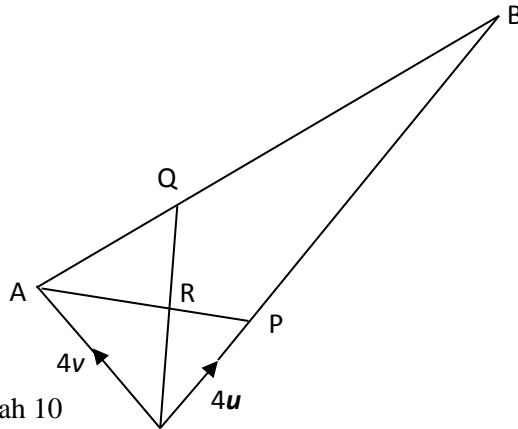

Diagram/ Rajah 10

It is given that $OP = \frac{1}{3}OB$, $AQ = \frac{1}{4}AB$, $\vec{OP} = 4\vec{u}$ and $\vec{OA} = 4\vec{v}$.

Diberi bahawa $OP = \frac{1}{3}OB$, $AQ = \frac{1}{4}AB$, $\vec{OP} = 4\vec{u}$ dan $\vec{OA} = 4\vec{v}$.

(a) Express in terms \vec{u} and/or \vec{v}

Ungkapkan dalam sebutan \vec{u} dan/atau \vec{v}

(i) \vec{AP}

(ii) \vec{OQ}

[4 marks/markah]

(b) (i) Given that $\vec{AR} = m\vec{AP}$, state \vec{AR} in terms of m , \vec{u} and \vec{v} .

Diberi bahawa $\vec{AR} = m\vec{AP}$, nyatakan \vec{AR} dalam sebutan m , \vec{u} dan \vec{v} .

(ii) Given that $\vec{RQ} = n\vec{OQ}$, state \vec{RQ} in terms of n , \vec{u} and \vec{v} .

Diberi bahawa $\vec{RQ} = n\vec{OQ}$, nyatakan \vec{RQ} dalam sebutan n , \vec{u} dan \vec{v} .

[2 marks/markah]

(c) Using $\vec{AQ} = \vec{AR} + \vec{RQ}$, find the value of m and of n .

[4 marks]

Menggunakan $\vec{AQ} = \vec{AR} + \vec{RQ}$, cari nilai bagi m dan n .

[4 markah]

11. Table 11, shows the corresponding values of two variables, x and y , obtained from an experiment. The variables x and y are related by the equation $y + kx^2 = hx$, where h and k are constants.

Jadual 11, menunjukkan nilai-nilai yang sepadan bagi dua pemboleh ubah, x dan y , yang diperolehi daripada suatu eksperimen. Pemboleh ubah x dan y dihubungkan oleh persamaan $y + kx^2 = hx$, dengan keadaan h dan k ialah pemalar.

x	0.5	1.0	1.5	2.0	2.5	3.0
y	0.95	2.55	2.55	3.18	3.75	4.20

Table/Jadual 11

- (a) Plot $\frac{y}{x}$ against x by using a scale of 2 cm to 0.5 units on the x-axis and 2 cm to 0.1 unit on the

$\frac{y}{x}$ -axis. Hence, draw the line of best fit. [4 marks]

Plot $\frac{y}{x}$ melawan x dengan menggunakan skala 2 cm kepada 0.5 unit pada paksi- x dan 2 cm kepada 0.1

unit pada paksi $\frac{y}{x}$. Seterusnya, lukis garis lurus penyuaian terbaik.. [4 marks]

- (b) Use the graph in (a) to find the values of
Gunakan graf di (a) untuk mencari nilai-nilai bagi

- (i) h ,
(ii) k ,
(iii) y when $x = 2.3$
 y apabila $x = 2.3$

[6 marks/markah]

SECTION C

12. Table 12, shows the unit prices of four components A, B, C and D, needed to produced a digital camera.

Jadual 12 menunjukkan harga unit bagi empat komponen A, B, C and D, yang diperlukan untuk menghasilkan kamera digital.

Component/ Komponen	Unit price/ Harga unit (RM)	
	Year/ Tahun 2011	Year/Tahun 2013
A	50	x
B	25	40
C	w	y
D	40	44

Table/Jadual 12

- (a) Given that the price index of component A for the year 2013 based on the year 2011 is 120, calculate the value of x . [2 marks]

Diberi indeks harga bagi komponen A pada tahun 2013 berasaskan tahun 2011 ialah 120, hitung nilai x . [2 markah]

- (a) The price index of component C for the year 2013 based on the year 2011 is 125. The unit price of component C in the year 2013 was RM20 more than its unit price in the year 2011. Calculate the value of w and of y . [3 marks]

Indeks harga bagi komponen C pada tahun 2013 berasaskan tahun 2011 ialah 125. Harga unit bagi komponen C dalam tahun 2013 ialah RM20 lebih daripada harga unitnya pada tahun 2011. Hitung nilai bagi w dan y . [3 markah]

- (b) The composite index of the cost to produce a digital camera for the year 2013 based on the year 2011 is 132. Calculate

Indeks gubahan bagi kos menghasilkan kamera digital pada tahun 2013 berasaskan tahun 2011 ialah 132. Hitung

- (i) the price of a digital camera in the year 2011 if its corresponding price in the year 2013 was RM1716.
harga bagi kamera digital pada tahun 2011 jika harga yang sepadan pada tahun 2013 ialah RM1716.

- (ii) the value of n if the ratio of components used to produce the digital camera is $1 : 3 : 4 : n$.
nilai bagi n jika nisbah komponen yang digunakan untuk menghasilkan kamera digital ialah $1 : 3 : 4 : n$. [5 marks/markah]

13(a) Diagram 13(a) shows $\triangle PQR$.

Rajah 13(a) menunjukkan $\triangle PQR$.

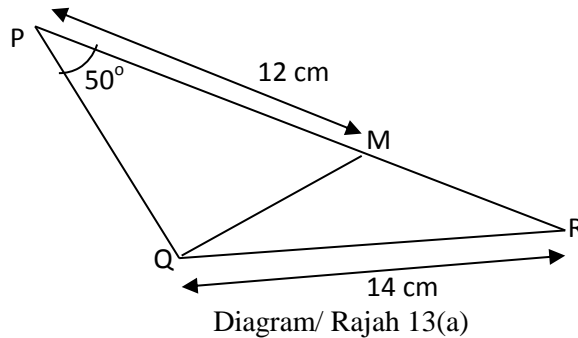

It is given that $PM = 12$ cm, $QR = 14$ cm and $\angle QPR = 50^\circ$. Point M lies on the side PR such that $3PM = 2PR$ and $\angle PQR$ is obtuse.

Diberi bahawa $PM = 12$ cm, $QR = 14$ cm dan $\angle QPR = 50^\circ$. Titik M terletak pada sisi PR dengan keadaan $3PM = 2PR$ dan $\angle PQR$ ialah cakak.

Calculate the length of QM .

Hitung panjang QM

[4 marks]

[4 markah]

(b) Diagram 13(b) shows a cuboid with square base $ABCD$.

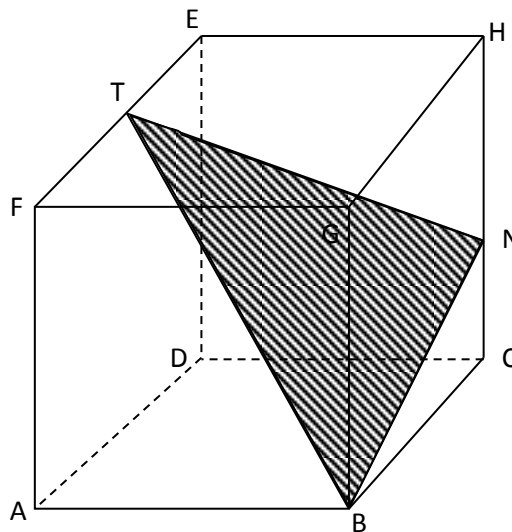

Diagram/ Rajah 13(b)

It is given that $AF = 12$ cm and $FE = 8$ cm. T is the midpoint of FE and point N lies on HC such that

$$HN = \frac{3}{4} HC.$$

Diberi bahawa $AF = 12$ cm dan $FE = 8$ cm. T ialah titik tengah FE dan titik N terletak pada HC dengan

$$\text{keadaan } HN = \frac{3}{4} HC.$$

Calculate the area of $\triangle TNB$.

[6 marks]

Hitung luas bagi $\triangle TNB$

[6 markah]

14. A factory produces two brands of fertiliser, *Super A* and *Super B*, from the mixture of two raw materials, *P* and *Q*. Each packet of *Super A* brand contains 500 g of materials *P* and 600 g of material *Q* while each packet of the *Super B* brand contains 800 g of material *P* and 300 g of material *Q*. The factory is supplied with 40 kg of material *P* and 24 kg of material *Q*. The number of packets of the *Super A* brand produced cannot be more than three times the number of packets of the *Super B* brand produced. On a certain day, the factory produces x packets of the *Super A* brand and y packets of *Super B* brand.

Sebuah kilang menghasilkan dua jenama baja, Super A dan Super B, daripada campuran dua bahan mentah, P dan Q. Setiap bungkusan jenama Super A mengandungi 500 g bahan P dan 600 g bahan Q manakala setiap bungkusan Super B mengandungi 800 g bahan P dan 300 g bahan Q. Kilang itu dibekalkan dengan 40 kg bahan P dan 24 kg bahan Q. Bilangan bungkusan jenama Super A yang dihasilkan tidak melebihi tiga kali bilangan bungkusan jenama Super B yang dihasilkan. Pada suatu hari tertentu, kilang itu menghasilkan x bungkusan jenama Super A dan y bungkusan jenama Super B.

- (a) Write three inequalities other than $x \geq 0$ and $y \geq 0$, which satisfy the given constraints. [3 marks]
Tulis tiga ketaksamaan, selain $x \geq 0$ dan $y \geq 0$, yang memenuhi semua kekangan diberi. [3 markah]
- (b) Hence, using a scale of 2 cm to 10 units on both axes, construct and shade the feasible region R which satisfies all the given constraints. [3 marks]
Seterusnya, dengan menggunakan skala 2 cm kepada 10 unit pada kedua-dua paksi, bina dan lorek rantau R yang memenuhi semua kekangan diberi. [3 markah]
- (c) Use your graph in (b) to find
Gunakan graf anda di (b) untuk mencari
- (i) the maximum profit that can be obtained by the factory if the profits obtained from the sales of a packet of the *Super A* brand and a packet of the *Super B* brand are RM6 and RM8 respectively .
keuntungan maksimum yang boleh diperolehi oleh kilang itu jika keuntungan daripada penjualan satu bungkusan jenama Super A dan satu bungkusan jenama Super B ialah RM6 dan RM8 masing-masing.
- (ii) the maximum number of packets produced for each brand if the number of packets of the *Super B* brand produced is equal to the number of packets of the *Super A* brand produced.
bilangan bungkusan maksimum yang dihasilkan bagi setiap jenama jika bilangan bungkusan jenama Super B yang dihasilkan sama dengan bilangan bungkusan jenama Super A yang dihasilkan. [4 marks/markah]

15. A particle moves in a straight line that passes through a fixed point O , with velocity of 20 ms^{-1} . Its acceleration, $a \text{ ms}^{-2}$, t seconds after passing through O , is given by $a = 8 - 2t$. The particle stops instantaneously after m seconds.

Suatu zarah bergerak di sepanjang suatu garis lurus dan melalui satu titik tetap O , dengan halaju 20 ms^{-1} . Pecutannya, $a \text{ ms}^{-2}$, t saat selepas melalui O , diberi oleh $a = 8 - 2t$. Zarah itu berhenti seketika selepas m saat.

Find/cari

- (a) the maximum velocity of the particle,
halaju maksimum bagi zarah itu,
- (b) the value of m .
nilai m
- (c) the total distance travelled in the first m second.
jumlah jarak yang dilalui dalam m saat pertama

[10 marks/markah]

PANDUAN JAWAPAN MODUL 2 MATEMATIK TAMBAHAN KERTAS 2

NO	JAWAPAN	NO	JAWAPAN
1	$h = \frac{1}{9}, \frac{3}{2}; k = \frac{-1}{24}, 1$	9	a) 1.1716 rad b) 47.29 cm c) 50.06 cm^2 , 67.07 cm^2
2	b) $m = 4, n = 3$	10	a) i) $4\mathbf{u} - 4\mathbf{v}$ ii) $3\mathbf{u} + 3\mathbf{v}$ b) i) $4m\mathbf{u} - 4m\mathbf{v}$ ii) $3n\mathbf{u} + 3n\mathbf{v}$ c) $m = \frac{1}{2}, h = \frac{1}{3}$
3	b) -0.36π	11	a) graf b) i) $h = 2; k = 0.2$ ii) 3.54
4	a) P(0, 5/2) ; R(-5/4, 0) b) $x^2 - 2x + y^2 - 4y + 1 = 0$ ii) touches the x-axis	12	a) $x = 60$ b) $w = 80; y = 100$ c) RM1300 ii) $n = 2$
5	a) 180π b) $n = 10$	13	a) 9.30 cm b) 54.15 cm^2
6	a) graf b) no. of solutions = 2	14	c) i) RM420 ii) $x = 26; y = 26$
7	a) 99 b) $\mu = 40, \sigma = 2$	15	a) i) 36 ms^{-1} ii) $n = 10$ b) 266 $\frac{2}{3}$ m
8	a) $m = 12; n = 3$ b) $p = 6; x = 3; t = 4$		

Answer *All* Questions
Jawab **semua** soalan

1 It is given that $f : x \rightarrow \frac{5}{2x-3}, x \neq h$.

Diberi bahawa $f : x \rightarrow \frac{5}{2x-3}, x \neq h$.

(a) State the value of h .
Nyatakan nilai bagi h

(b) Find $f^{-1}(x)$.

[3 marks]

Jawapan:
Answer

(a)

(b)

2 It is given that the function $g : x \rightarrow 1-2x$ and the function $f : x \rightarrow kx^2 + m$, such that k and m are constants. If the composite function fg is given by $fg : x \rightarrow x^2 - x + 5$, find the value of k and of m .

Diberi fungsi $g : x \rightarrow 1-2x$ dan fungsi $f : x \rightarrow kx^2 + m$, where k dan m adalah pemalar. Jika fungsi gubahan fg diberi sebagai $fg : x \rightarrow x^2 - x + 5$, Cari nilai k dan m

[3 marks]

Answer:
Jawapan:

3. Given the function $f : x \rightarrow |\sqrt[4]{x+4}|$, find the values of x such that $f(x) = 2$.
 Diberi fungsi $f : x \rightarrow |\sqrt[4]{x+4}|$, cari nilai-nilai x dengan keadaan $f(x) = 2$.

[3marks]

Answer:

Jawapan:

- 4 The roots of a quadratic equation $4x^2 + px + p + 3 = 0$ are α and β . If $\alpha^2 + \beta^2 = \frac{-1}{4}$. Find the values of p .
 Punca-punca persamaan kuadratik $4x^2 + px + p + 3 = 0$ ialah α dan β . Jika $\alpha^2 + \beta^2 = \frac{-1}{4}$. Cari nilai-nilai p .

[4 marks]

Answer:

Jawapan:

- 5 Given $\frac{\alpha}{2}$ and $\frac{\beta}{2}$ are the roots of $3x^2 + 6x - 5 = 0$. Form the quadratic equation if the roots are $\frac{2}{\alpha}$ and $\frac{2}{\beta}$

Diberi $\frac{\alpha}{2}$ dan $\frac{\beta}{2}$ ialah punca bagi persamaan $3x^2 + 6x - 5 = 0$. Bentukkan persamaan kuadratik jika puncanya adalah $\frac{2}{\alpha}$ dan $\frac{2}{\beta}$.

[3 marks]

Answer:

Jawapan:

- 6 Determine the range of the values of m if the straight line $f(x) = 3 + mx$ intersects the graph of the quadratic function $f(x) = x^2 - 4x + 4$ at two different points.
 Tentukan julat nilai m jika garis lurus $f(x) = 3 + mx$ memotong graf fungsi $f(x) = x^2 - 4x + 4$ pada dua titik yang berlainan. [4 marks]

Answer: / Jawapan:

-
- 7 Given that $9(\sqrt[3]{3(6h+12)}) = (\frac{1}{243})^{3h-6}$
 Diberi bahawa $9(\sqrt[3]{3(6h+12)}) = (\frac{1}{243})^{3h-6}$

Find the value of h ,
 Cari nilai bagi h ,

[3 marks]

Answer:
 Jawapan:

-
- 8 Solve the equation $\log_3 4x - \log_3(2x - 1) = 1$ [3 marks]
 Selesaikan persamaan $\log_3 4x - \log_3(2x - 1) = 1$ [3 markah]
 Answer:
 Jawapan:

- 9 There are 12 terms in an arithmetic progression. The sum of the first 6 terms is 42. The sum of the first 12 terms exceeds the sum of the first 6 terms by 114. Find the common difference and the first term.

Satu jangjang arithmatik mempunyai 12 sebutan. Jumlah 6 sebutan pertama ialah 42. Jumlah 12 sebutan melebihi jumlah 6 sebutan pertama sebanyak 114. Kira nilai beza sepunya dan sebutan pertama.

[4 marks]

Answer:

Jawapan:

-
- 10 Given that $2, 3k, k^2 + 3k$ are three consecutive terms of geometric progression, find the possible values of k .

Diberi bahawa $2, 3k, k^2 + 3k$ adalah tiga sebutan berturutan dalam satu jangjang arithmetic. Cari nilai-nilai yang mungkin bagi k

[3 markah]

Jawapan/Answer

-
- 11 If the sum of the first n terms of an arithmetic progression is given by $S_n = n^2(2n - 3)$, find the common difference.

Jika jumlah sebutan pertama bagi suatu jangjang arithmetic diberi sebagai $S_n = n^2(2n-3)$, Cari beza sepunya.

[3 marks]

Answer Jawapan

- 12 Diagram 12 shows a graph of $\frac{1}{y}$ against x .

Rajah 12 menunjukkan graf $\frac{1}{y}$ melawan x .

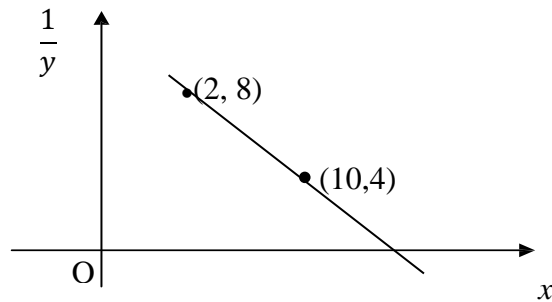

DIAGRAM 12/ Rajah 12

The variables x and y are related by the equation $y = \frac{k}{2x+h}$, where k and h are constants.

Calculate the value of k and of h . [3 marks]

Pembolehubah x dan y dihubungkan dengan persamaan $y = \frac{k}{2x+h}$, dimana k dan h pemalar.

Kira nilai k dan nilai h

Answer:

Jawapan:

- 13 Given $\vec{OA} = 3\mathbf{a} + 8\mathbf{b}$, $\vec{OB} = (\sqrt{k} - 1)\mathbf{a} - \mathbf{b}$ and $\vec{OC} = 7\mathbf{a} + 5\mathbf{b}$, where k is a constant. Find the value of k if the points A , B and C are collinear.

Diberi $\vec{OA} = 3\mathbf{a} + 8\mathbf{b}$, $\vec{OB} = (\sqrt{k} - 1)\mathbf{a} - \mathbf{b}$ dan $\vec{OC} = 7\mathbf{a} + 5\mathbf{b}$, dengan keadaan k ialah pemalar. Cari nilai k jika titik A , B dan C adalah segaris. [3 marks]

Answer/Jawapan:

14

Diagram, 11 shows $\vec{OA} = \vec{a}$ and $\vec{OB} = \vec{b}$ drawn in 1 unit square.

Express \vec{PQ} in terms of \vec{a} and \vec{b} and find $\left| \vec{PQ} \right|$

Rajah 11 menunjukkan $\vec{OA} = \vec{a}$ dan $\vec{OB} = \vec{b}$ dilukis pada grid

1 unit persegi. Nyatakan \vec{PQ} dalam sebutan \vec{a} and \vec{b} dan cari $\left| \vec{PQ} \right|$

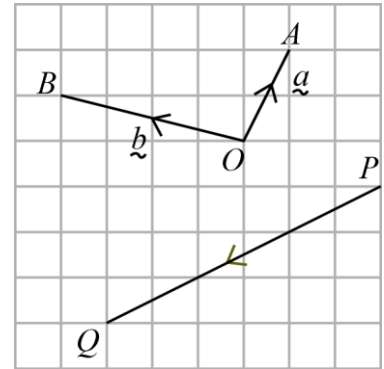

[3 marks]

Answer/ Jawapan

15 The coordinates of points L and M are $(-2, 5)$ and $(4, -1)$ respectively. A point K moves such that $LK : KM = 3 : 1$. Find the equation of the locus of point K .

Koordinat bagi titik L dan titik M masing-masing ialah $(-4, 5)$ dan $(6, -1)$. Satu titik K bergerak dengan $LK : KM = 3 : 1$. Cari persamaan lokus bagi titik K .

[3 marks]

Answer / Jawapan:

16

Solve the equation $\cot^2 \theta + \frac{2}{\sin^2 \theta} = 3$, for $0^\circ \leq \theta \leq 360^\circ$

Selesaikan $\cot^2 \theta + \frac{2}{\sin^2 \theta} = 3$, for $0^\circ \leq \theta \leq 360^\circ$

[3 marks]

Answer

Jawapan

- 17 Given $\cos 2\alpha = k$, and $180^\circ \leq 2\alpha \leq 360^\circ$ express in terms k
 (i) $\cos 4\alpha$ (ii) $\sin \alpha$

[3 marks]

Answer

Jawapan

Answer / Jawapan

(a)

(b)

- 18 Given $\int_k^6 f(x)dx = -4$ and $\int_6^k [f(x) - 5]dx = 12$, find the value of k .

Diberi $\int_k^6 f(x)dx = -4$ dan $\int_6^k [f(x) - 5]dx = 12$, cari nilai k .

[3 marks]

Answer:

Jawapan:

- 19 Diagram 19 shows a shaded region that bounded by the curve $y = \sqrt{x+1}$, and line $x = k$ and x -axis. When the shaded region revolved 360° through x -axis the volume generated is 2π . Find the value of k
 Rajah 19 menunjukkan rantau berlorek yang dibatasi oleh lengkung $y = \sqrt{x+1}$, garis $x = k$ dan paksi- x . Apabila rantau itu diputar 360° pada paksi- x , isipadu yang dijanakan 2π unit³. Carikan nilai k .

[3 markah]

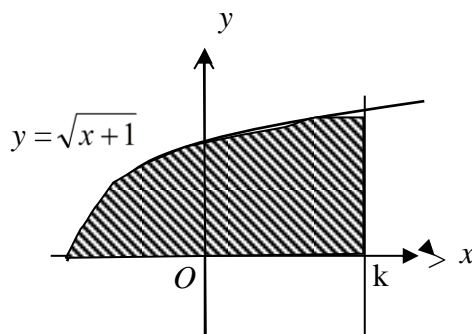

Diagram/Rajah 19

Answer:

Jawapan:

- 20 Diagram 20 shows two sectors OAB and OCD with centre O .
Rajah 20 menunjukkan dua sektor OAB and OCD dengan pusat O

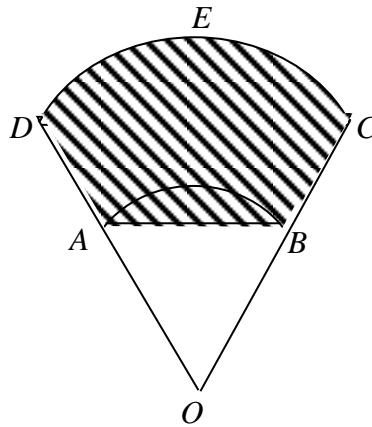

Diagram 20

If $\angle COD = 0.92$ rad, $BC = 5$ cm and perimeter of sector OAB is 20.44 cm, Calculate the area of the shaded region $ABCED$ (Use $\pi = 3.142$)

Jika $\angle COD = 0.92$ rad, $BC = 5$ cm dan perimeter sector OAB ialah 20.44 cm. Kira luas kawasan berlorek $ABCED$ (Gunakan $\pi = 3.142$) [4 marks]

Answer / Jawapan:

- 21 The surface area of a cubes with the sides x cm increase at the rates of $10 \text{ cm}^2\text{s}^{-1}$. Find the rate of change of the volume of the cubes when the sides is 5 cm
Luas permukaan sebuah kubus yang bersisi x cm bertambah dengan kadar $10 \text{ cm}^2\text{s}^{-1}$. Cari kadar perubahan isipadu kubus itu pada ketika sisinya ialah 5 cm

[4 markah]

Answer /Jawapan:

- 22 Diagram 22 shows six cards of different letters.
Rajah 22 menunjukkan enam kad dengan huruf-huruf yang berlainan.



Rajah 22 / Diagram 22

- (a) Find the number of possible arrangements, in a row, of all the cards.
Cari bilangan susunan yang mungkin di dalam satu baris jika kesemua kad digunakan.
- (b) Find the number of these arrangements in which the letters W, S and M are side by side.
Cari bilangan susunan jika huruf W, S dan M mesti sebelah menyebelah.

[3 marks]

Answer:

Jawapan:

-
- 23 Given the data of integers 1, 2, 4, 6, 9, 12 and 14, 16 Find the
Diberi data yang terdiri dari integer – integer 1, 2, 4, 6, 9, 12 dan 14, 16 . Cari nilai

(a) range,

 julat

(b) the interquartile range.

 Julat antara kuartil

[3 marks]

Answer:

Jawapan:

24. The probabilities that Abu and Chong are selected to play for team A are $\frac{1}{4}$ and $\frac{3}{5}$ respectively. The probability that Abu is chosen as captain is $\frac{3}{8}$ whereas if the probability that Chong selected as a captain is $\frac{5}{9}$. Find the probability that

Kebarangkalian bahawa Abu dan Chong dipilih untuk bermain bagi pasukan A ialah $\frac{1}{4}$ dan $\frac{3}{5}$ masing –masing. Jika Abu dipilih, kebarangkalian bahawa beliau dipilih sebagai ketua ialah $\frac{3}{8}$ manakala jika Chong dipilih, kebarangkalian beliau menjadi ketua ialah $\frac{5}{9}$. Cari kebarangkalian bahawa

- (a) Both of them are selected to play for team A,
Kedua-dua mereka dipilih untuk bermain bagi pasukan A,
- (b) None of them becomes captain if both are selected
Tidak seorang pun daripada mereka menjadi ketua jika kedua-dua mereka dipilih.

[3 marks]

Answer:

Jawapan:

25

X is a discrete random variable such that, $X \sim B(4, \frac{1}{6})$. Find

X ialah pemboleh ubah rawak diskrit dengan keadaan, $X \sim B(4, \frac{1}{6})$. Cari

- (a) the mean / min
b) $P(x \leq 2)$

[3 marks]

Answer:

Jawapan:

**END OF QUESTION PAPER
KERTAS SOALAN TAMAT**

Panduan Jawapan

No	Answer	No	Answer
1	a) $h = \frac{3}{2}$ b) $f^{-1} = \frac{5+3x}{2x}$	14	\rightarrow $PQ = -2a + b$ $\sim \sim$ $ PQ = \sqrt{45}$
2	$k = \frac{1}{4}$ $m = \frac{19}{4}$	15	$4x^2 + 4y^2 - 38x + 9y + 62 = 0$
3	$x = 12$, $x = -20$	16	$\theta = 60^\circ, 120^\circ, 240^\circ, 300^\circ$
4	$p = 10, p = -2$	17	(a) $2k^2 - 1$ (b) $\sin \alpha = \sqrt{\frac{1-k}{2}}$
5	$5x^2 - 6x - 3 = 0$	18	$k = \frac{22}{5}$
6	$m \leq 2, m \geq 6$	19	$k = -1$
7	$h = \frac{24}{17}$	20	$r = 7$ Area = 43.7cm^2
8	$x = \frac{3}{2}$	21	$12.5\text{cm}^3\text{s}^{-1}$
9	$a = 2, d = 2$	22	(a) 720 (b) 144
10	$k = 2, k = 1$	23	(a) 15 (b) 10
11	$d = 6$	24	$\frac{203}{480}$
12	$QP = -2a + b$ $\left \begin{array}{c} \rightarrow \\ QP \end{array} \right = \sqrt{45}$	25	(a) $\frac{2}{3}$ (b) 0.9838
13	$k = 169$		

SECTION A
BAHAGIAN A

1. Find the points of intersection of the straight line $\frac{x}{3} - \frac{y}{2} = \frac{8}{3}$ and a curve $x(1+y) = 2y+2$

Cari titik-titik persilangan bagi garis lurus $\frac{x}{3} - \frac{y}{2} = \frac{8}{3}$ dan lengkung $x(1+y) = 2y+2$

[5 marks/markah]

2. Diagram 2 shows the curve $y = 2(x-1)^2 - q$ and $y = x^2 - 2px + 9 - q$ where p and q are constants. Both the curves intercept the x -axis at $x = -2$ and $x = 4$.

Rajah 2 menunjukkan lengkung $y = 2((x-1)^2 - q$ dan lengkung $y = (x-p)^2 - (q-9)$ di mana p dan q adalah pemalar. Kedua-dua lengkung itu menyalang paksi- x pada $x = -2$ dan $x = 4$.

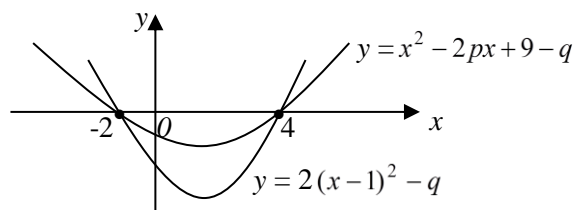

Diagram/Rajah 2

Find/cari

- (a) the values of p and of q .
nilai p dan q .

[3 marks/markah]

- (b) The minimum point of each curve.
Titik minimum bagi setiap lengkung itu.

[3 marks/markah]

3. Prove the identity
Buktikan identiti

$$\left(\frac{1 + \cos 2x}{\cos x} - \frac{1 - \cos 2x}{\sin x} \right)^2 = 4(1 - \sin 2x)$$

Hence, solve the trigonometric equation $\left(\frac{1 + \cos 2x}{\cos x} - \frac{1 - \cos 2x}{\sin x} \right)^2 = \sin 2x$

for all angles between 0° and 180° .

Seterusnya, selesaikan persamaan trigonometri $\left(\frac{1 + \cos 2x}{\cos x} - \frac{1 - \cos 2x}{\sin x} \right)^2 = \sin 2x$

untuk semua sudut di antara 0° dan 180° .

[6 marks/ markah]

4. En. Yusuf was offered the post of a project manager in two companies, A and B. In company A, he was offered a salary of RM2 500 per month and a yearly increment of RM400. In company B, he was offered a salary of RM2 800 per month and a yearly increment of 10% of his salary for the preceding year.

En. Yusuf ditawarkan pekerjaan sebagai pengurus projek untuk dua syarikat, A dan B.

Di syarikat A, dia ditawarkan gaji RM 2 500 sebulan dan kenaikan tahunan RM400. Di syarikat B, dia ditawarkan gaji RM2 800 sebulan dengan kenaikan 10% daripada gajinya untuk tahun berikutnya.

- (a) Based on the salaries and increments offered by both companies, determine which company's pay scheme follows

Berdasarkan gaji dan kenaikan gaji yang ditawarkan oleh kedua-dua syarikat, tentukan skim gaji syarikat yang mengikuti

- (i) An arithmetic progression
Janjang aritmetik.
(ii) A geometric progression.
Janjang geometri.

[3 marks/markah]

- (b) Find his monthly income in the fifth year of his work if he works

Cari gaji bulanan pada tahun kelima bagi pekerjaannya jika dia bekerja

- (i) In company A
di syarikat A
(ii) In company B.
di syarikat B.

[3 marks/markah]

- (c) Find the minimum number of years of his service in company B for his total salary to reach at least RM40 000

Cari bilangan tahun yang minimum bagi perkhidmatannya di syarikat B supaya jumlah gaji mencapai sekurang-kurangnya RM40 000.

[2 marks/markah]

5. Diagram 5 shows a triangle OPQ . Point $S(-1, 8)$ lies on the line PQ .

Rajah 5 menunjukkan sebuah segitiga OPQ . Titik $S(-1, 8)$ terletak di atas garis PQ .

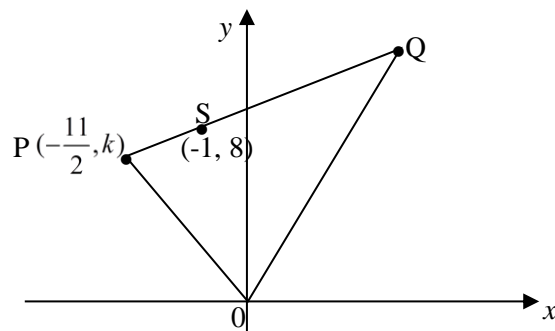

- (a) Point T is a moving point such that its distance from point S is always $7\frac{1}{2}$ unit. Find the equation of the locus T .

Titik T adalah titik yang bergerak dengan keadaan jaraknya dari S sentiasa $7\frac{1}{2}$ unit.

Cari persamaan lokus bagi T .

[3 marks/markah]

- (b) Given that the point P and point Q lie on the locus of T . Calculate
Diberi bahawa titik P dan titik Q berada pada lokus T . Hitungkan

- (i) the value of k .
nilai bagi k .
(ii) the coordinates of Q .
koordinat titik Q .

[5 marks/markah]

6. Table 6 shows the marks Khairul and Ameer obtained in trial examination for elective Science papers .

Jadual 6 menunjukkan markah-markah yang diperoleh oleh khairul dan Ameer dalam peperiksaan percubaan untuk mata pelajaran elektif Sains .

Khairul	Ameer
85	90
87	89
82	70
90	95

Table 6

- (a) Find mean marks for Khairul and Ameer.
Cari markah min bagi Khairul and Ameer.
- (b) Find the standard deviation for the marks obtained by Khairul and Ameer.
Cari sisihan piawai bagi markah yang diperoleh oleh Khairul and Ameer.
- (c) If their class teacher wish to give a prize for the best student , suggest who will get the prize.
Give your reason.
Jika guru kelas ingin memberi hadiah kepada pelajar terbaik, cadangkan siapa yang akan mendapat hadiah tersebut.
Beri alasan anda.

[7 marks/markah]

SECTION B
BAHAGIAN B

7. Diagram 7 shows part of a curve $y = x^2$ and the tangent to the curve at point $A(2, 4)$.
Rajah 7 menunjukkan sebahagian daripada lengkungan $y = x^2$ dan tangen kepada lengkungan itu pada titik $A(2, 4)$.

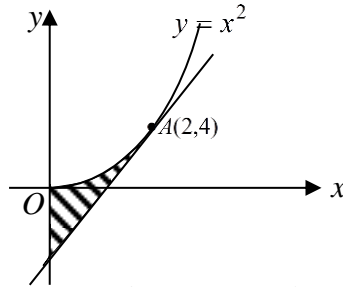

Diagram / Rajah 7

- (a) Find the equation of the tangent.
Cari persamaan tangen itu [3 marks/markah]
- (b) Find the area of the shaded region.
Carikan luas rantau berlorek. [3 marks/markah]
- (c) Calculate the volume of revolution, in terms of π , when the shaded region is rotated through 360° about the y -axis.
Hitungkan isipadu janaan, dalam sebutan π , apabila rantau yang berlorek diputarakan melalui 360° pada paksi- y . [4 marks/markah]

8. Diagram 8 shows a triangle OAB . The straight lines AM and OK intersect at point L .

It is given that $\vec{OA} = 2\vec{x}$, $\vec{OB} = 14\vec{y}$, $OM : MB = 5 : 2$ and $AK = \frac{1}{4}AB$.

Rajah 8 menunjukkan sebuah segitiga OAB . Garis lurus-garis lurus AM dan OK bersilang pada titik L . Diberi bahawa $\vec{OA} = 2\vec{x}$, $\vec{OB} = 14\vec{y}$, $OM : MB = 5 : 2$ dan $AK = \frac{1}{4}AB$.

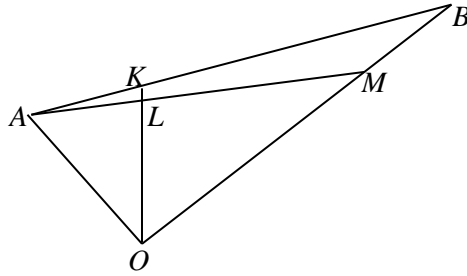

Diagram /Rajah 8

- (a) Express each of the following vectors in terms of \vec{x} and \vec{y}

Ungkapkan setiap vector berikut dalam sebutan \vec{x} dan \vec{y}

- (i) \vec{OM}
(ii) \vec{AK}

[3 marks/markah]

- (b) Given that $\vec{AL} = p\vec{AM}$ and $\vec{KL} = q\vec{KO}$, express

Diberi bahawa $\vec{AL} = p\vec{AM}$ dan $\vec{KL} = q\vec{KO}$, ungkapkan

- (i) \vec{AL} in terms of p , \vec{x} and \vec{y}
 \vec{AL} dalam sebutan p , \vec{x} dan \vec{y}
- (ii) \vec{KL} in terms of q , \vec{x} and \vec{y}
 \vec{KL} dalam sebutan q , \vec{x} dan \vec{y}

[3 marks/markah]

- (c) Using vectors \vec{AK} , \vec{AL} and \vec{LK} , find the value of p and of q .

Dengan menggunakan vector-vector \vec{AK} , \vec{AL} dan \vec{LK} , cari nilai p dan nilai q .

[4 marks/markah]

9. Use graph paper to answer this question.
Gunakan kertas graf untuk menjawab soalan ini.

Table 9 below shows the values of two variables, x and y obtained from an experiment. It is known that x and y are related by the equation $4a^2x = (y-b)^2$, where a and b are constants.

Jadual 9 menunjukkan nilai-nilai pembolehubah x dan y yang diperolehi daripada satu ujikaji. Diberi bahawa x dan y dihubungkan oleh persamaan $4a^2x = (y-b)^2$, dengan keadaan a dan b adalah pemalar.

x	9	16	25	36	49	64
y	3.7	4.13	4.5	4.9	5.3	5.65

Table 9/ Jadual 9

- (a) Plot y against \sqrt{x} , by using a scale of 2 cm to 1 unit on \sqrt{x} -axis and 2 cm to 0.5 unit on y -axis. Hence, draw the line of best fit.

Plotkan y melawan \sqrt{x} , dengan menggunakan skala 2 cm kepada 1 unit untuk paksi- \sqrt{x} dan 2 cm kepada 0.5 unit untuk paksi- y . Seterusnya lukiskan garis lurus penyuaiian terbaik.

[4 marks/markah]

- (b) Use the graph from (a) to find the value of
Gunakan graf dari (a) untuk mencari nilai

- (i) a ,
(ii) b .
(iii) y when $x = 30$

[6 marks/markah]

10. Diagram 10 shows two identical circles with centres, F and H , and radius 12 cm. The circles intersect at point E and point G .

Rajah 10 menunjukkan dua buah bulatan yang serupa berpusat, F dan H , dan berjari 12 cm. Bulatan-bulatan itu bersilang di titik E dan titik G .

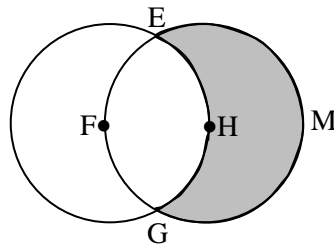

Diagram /Rajah 10

By using $\pi = 3.142$, calculate
Dengan menggunakan $\pi = 3.142$, hitungkan

- (a) $\angle EFG$ in radians,
 $\angle EFG$ dalam radian, [2 marks/markah]
- (b) the perimeter of the shaded region EHG M,
perimeter kawasan berlorek EHG M. [4 marks/markah]
- (c) the area of the shaded region.
luas kawasan berlorek. [4 marks/markah]

11. The height of male students in a college are normally distributed with a mean of 164 cm and a standard deviation of 15 cm.

Tinggi pelajar lelaki di sebuah kolej adalah bertaburan normal dengan min 164 cm dan sisihan piawai 15cm.

- (a) A male student from the college is selected at random. Calculate the probability that his height is less than 170 cm.

Seorang pelajar lelaki dari kolej itu diipilih secara rawak. Hitung kebarangkalian bahawa tingginya adalah kurang daripada 170 cm.

[3 marks/markah]

- (b) If 15% of the tallest among the male students are selected to undergo a basketball training program, calculate the minimum height of the male students selected.

Jika 15% daripada yang tertinggi di kalangan pelajar lelaki dipilih untuk menjalankan satu program latihan bola keranjang, hitung tinggi minimum bagi pelajar lelaki yang dipilih.

[3 marks/markah]

- (c) If 8 male students are chosen at random, find the probability that at most 3 students have height less than 170 cm.

Jika 8 pelajar lelaki dipilih secara rawak, cari kebarangkalian bahawa paling banyak 3 pelajar mempunyai tinggi kurang daripada 170 cm.

[4 marks/markah]

SECTION C
BAHAGIAN C

12. Diagram 12 shows triangles NKJ, NMK and MLK. It is given that $LK = KJ = 6$ cm, $NJ = 12$ cm, $\angle NJK = 60^\circ$, $\angle MNK = 30^\circ$ and $\angle NMK = 110^\circ$.

The area of $\triangle KLM$ is 16 unit².

Rajah 12 menunjukkan segitiga-segitiga NKJ, NMK dan MLK. Diberi bahawa $LK = KJ = 6$ cm, $NJ = 12$ cm, $\angle NJK = 60^\circ$, $\angle MNK = 30^\circ$ dan $\angle NMK = 110^\circ$.

Luas $\triangle KLM$ ialah 16 unit².

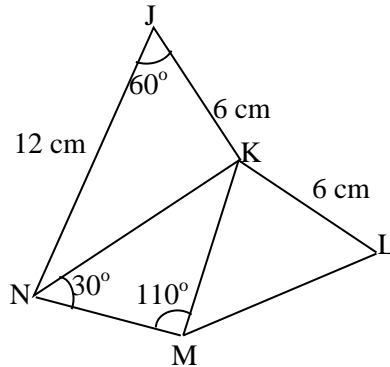

Diagram/ Rajah 12

- (a) Calculate, correct to 4 significant figures,
Hitungkan, betul kepada 4 angka bererti,
- (i) The length, in cm, of KN,
Panjang, dalam cm, bagi KN,
 - (ii) The length, in cm, of KM,
Panjang, dalam cm, bagi KM,
 - (iii) $\angle MKL$.
- [6 marks/markah]
- (b) From the side JN , a triangle is formed such that $\angle JNP = 40^\circ$ and $JP = 8.5$ cm.
Dari sisi JN , sebuah segitiga dibina dengan keadaan $\angle JNP = 40^\circ$ $JP = 8.5$ cm.
- (i) Calculate the two possible values of $\angle JPN$
Hitungkan dua nilai yang mungkin bagi $\angle JPN$.
 - (ii) Using the acute angle JPN , calculate the length, in cm, of NP .
Dengan menggunakan sudut tirus JPN , hitungkan panjang, dalam cm, bagi NP .

[4 marks/markah]

13. Table 13 shows the price indices of four commodities in the year 2008 using 2004 as the base year and the number of workers in the factory .

Jadual 12 menunjukkan indeks harga bagi empat barangan pada tahun 2008 dengan menggunakan 2004 sebagai tahun asas dan bilangan pekerja dalam kilang.

<i>Commodity/ barangan</i>	Price index in 2008 based on 2004 <i>Indeks harga pada 2008 berasaskan 2004</i>	Number of workers <i>Bilangan pekerja</i>
<i>A</i>	105	30
<i>B</i>	<i>m</i>	40
<i>C</i>	125	60
<i>D</i>	140	<i>n</i>

Table 13/ *Jadual 13*

- (a) Given the price of commodity B in the year 2008 is RM50 and the price in 2004 is RM40. Find the value of *m*.
Diberi harga barangan B pada tahun 2008 ialah RM50 dan harga pada tahun 2004 ialah RM40. Kirakan nilai m.
- [2 marks/markah]
- (b) Find the value of *n* such that the composite index for the prices of these commodities in the year 2008 based on the year 2004 is 123.
Cari nilai n dengan keadaan indeks gubahan bagi harga barangan itu pada tahun 2008 berasaskan tahun 2004 ialah 123.
- [3 marks/markah]
- (c) It is predicted that the price indices for commodities A, C, and D will increase by 10%, 15% and 5% respectively from the year 2008 to the year 2010 while that of commodity B remain unchanged.
Indeks harga bagi barangan A, C dan D dijangka bertambah sebanyak 10%, 15% dan 5% masing-masing dari tahun 2008 ke tahun 2010 manakala barangan B tidak berubah.
Calculate
Hitungkan
- (i) the price index of each commodity in the year 2010 based on the year 2004.
Indeks harga bagi setiap barangan itu pada tahun 2010 berasaskan tahun 2004.
- (ii) The composite index in the year 2010 based on the year 2004.
Indeks gubahan pada tahun 2010 berasaskan tahun 2004.
- [5 marks/markah]

14. A particle moves along a straight line which passes through a fixed point O . Its velocity, $v \text{ ms}^{-1}$, t seconds after leaving O , is given by $v = pt - t^2$, where p is a constant. The velocity of the particle is maximum when $t = 3$ seconds.
Sebutir zarah bergerak di sepanjang garis lurus melalui satu titik tetap O . Halajunya, $v \text{ ms}^{-1}$, t saat selepas meninggalkan O , diberi oleh $v = pt - t^2$, di mana p adalah pemalar. Halaju zarah maksimum ketika $t = 3$ saat.

Find/Cari

- (a) The value of p .
Nilai bagi p . [2 marks/markah]
- (b) The acceleration of the particle when it passes through point O again.
Pecutan zarah apabila ia melalui titik O semula. [3 marks/markah]
- (c) the time when the particle reverse its direction and hence, find the total distance travelled by the particle in the first 12 seconds.
Masa ketika zarah bertukar arah dan seterusnya cari jumlah jarak, dalam m , yang dilalui oleh zarah dalam 12 saat yang pertama. [5 marks/markah]
15. Cik Nur Diyanah bakes two types of cakes, P and Q. The cake P needs 120g of butter and 500 g of flour. The cake Q needs 240 g of butter and 400 g of flour. Cik Nur Diyanah has only 8.4 kg of butter and 20kg of flour to bake x cake P and y cake Q. The number of the cake P is not more than two times the number of the cake Q.
Cik Nur Diyanah membuat dua jenis kek, P dan Q. Sebiji kek P memerlukan 120g mentega dan 500 g tepung. Sebiji kek Q memerlukan 240 g mentega dan 400 g tepung. Cik Nur Diyanah mempunyai hanya 8.4 kg mentega dan 20kg tepung untuk membuat x biji kek P dan y biji kek Q. Bilangan kek P tidak melebihi dua kali bilangan kek Q.
- (a) State three inequalities, other than $x \geq 0$ and $y \geq 0$, that satisfy the above constraints.
Nyatakan tiga ketaksamaan, selain $x \geq 0$ dan $y \geq 0$, yang memenuhi semua kekangan di atas. [3marks/markah]
- (b) Using a scale of 2 cm to 10 units on the x – axis and 2 cm to 5 units on the y - axis, construct and shade the region R the satisfies all the above constraints.
Dengan menggunakan skala 2 cm kepada 10 unit pada paksi- x dan 2 cm kepada 5 unit kepada paksi- y , bina dan lorek rantau R yang memenuhi semua kekangan di atas. [3 marks/markah]
- (c) Based on your graph,
Berdasarkan graf anda,
- (i) Find the maximum profit obtained by Cik Nur Diyanah if the profits obtained from the sales of a cake P and a cake Q are RM10 and RM5 respectively.
Cari keuntungan maksimum yang di peroleh Cik Nur Diyanah jika keuntungan daripada jualan sebiji kek P dan jualan sebiji kek Q ialah RM10 dan RM5 masing-masing.
- (ii) If the number of the cake Q baked exceeds the number of the cake P baked by 7, find the maximum number of the cake P and the maximum number of the cake Q that are baked.
Jika bilangan kek Q yang dibuat melebihi bilangan kek P sebanyak 7, cari bilangan maksimum kek P dan bilangan maksimum kek Q yang di buat. [4 marks/markah]

PANDUAN JAWAPAN SET 3

1	$(2, -4), \left(\frac{13}{2}, -1\right)$	2	(a) $p = 1, q = 18$ (b) $(1, -18), (1, -10)$
3	(b) $x = 116.57^\circ, 153.44^\circ$	4	(a) Company A: AP Company B: GP (b) RM4 100, RM4 099.48 (c) $n = 10$
5	(a) $4x^2 + 4y^2 + 8x - 64y + 35 = 0$ (b) (i) $k = 2$ (ii) $Q\left(\frac{7}{2}, 14\right)$	6	(a) 86, 86 (b) 2.915, 9.513 Khairul will get the prize because his marks are more consistent as his standard deviation is less than Ameer's std. deviation
7	(a) $y = 4x - 4$ (b) $\frac{8}{3}$ (c) $\frac{8}{3}\pi$	8	(a)(i) $\vec{OM} = 10\vec{y}$ (ii) $\vec{AK} = \frac{7}{2}\vec{y} - \frac{1}{2}\vec{x}$ (b)(i) $\vec{AL} = -2p\vec{x} + 10p\vec{y}$ (ii) $\vec{KL} = -\frac{3}{2}q\vec{x} - \frac{7}{2}q\vec{y}$ (c) $p = \frac{7}{22}, q = \frac{1}{11}$
9	(b) $y = 2a\sqrt{x} + b$ (i) $a = 0.2$ (ii) $b = 2.45$ (iii) $y = 4.7$	10	(a) 2.0947 rad. (b) 75.408 (c) 275.5188
11	(a) 0.6554 (b) 179.54 (c) 0.09997	12	(a) (i) 0.39 (ii) 5.528 (iii) 74.75° (b) $65.16^\circ, 114.84^\circ$ 12.76
13	(a) $I = \frac{50 \times 100}{40} = 125$ (b) $n = 20$ (c)(i) $I_A = 115.5$ $I_C = 143.75$ $I_D = 147$ (ii) 133.53	14	(a) $p = 6$ (b) 12 (c) $t = 6$ 216 m
15	(a) $x + 2y \leq 70$ $5x + 4y \leq 200$ $x \leq 2y$ (c)(i) RM 355 (ii) $x = 18, y = 25$		